

This Manual Covers Lycoming Specific Ignition System Installation

Disclaimer

These products do not conform to any recognized set of standards or certifications for aviation applications.

This ECU is not waterproof and will not function as designed if moisture invades the enclosure or power/ ground connections are interrupted.

Failure of this unit may result in a complete loss of engine power.

Use of these products on amateur built/ experimental aircraft is at the discretion of the buyer who accepts full responsibility for any consequences resulting from its use. Since Racetech Inc. cannot control the installation, programming, application environment or use of its products, we accept no responsibility for damage, loss or personal injury resulting from the use of SDS products. By using SDS products, the user understands and accepts this.

If any user does not agree to this disclaimer, they may return the system/ parts in new condition for a full refund.



Coil Pack(s)

Most aviation systems will come with either a gray four cylinder coil pack or black six cylinder coil pack. The grey ones have integral drive transistors, the black ones use an external drive module bolted to the coil mount. These are fired in a waste spark configuration, which means two plugs are fired at the same time. One plug is fired on compression, the other on exhaust when no mixture is present. Both types may be engine mounted in any orientation. We offer several mounting brackets for Lycoming applications and flat type bases for firewall mounting.

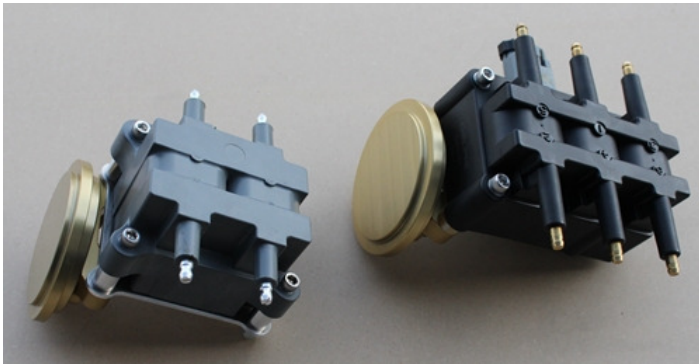

4 and 6 cylinder coil packs with rear mag mounts

Important! If you're replacing the left magneto, be sure to remove the drive gear, coupler and bearing on some models from the case before installing the SDS mag covers or coil mounts. Use a thin layer of RTV on the mag covers before tightening the nuts.

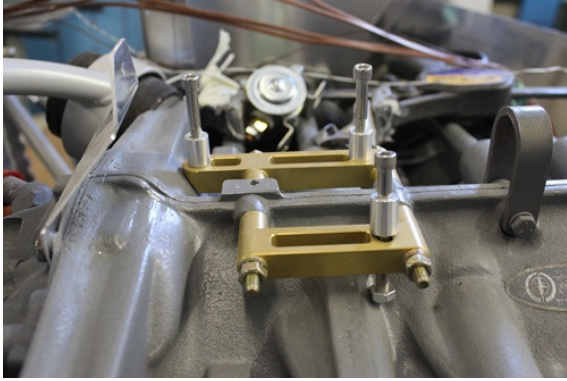

4 cylinder top case coil pack mount

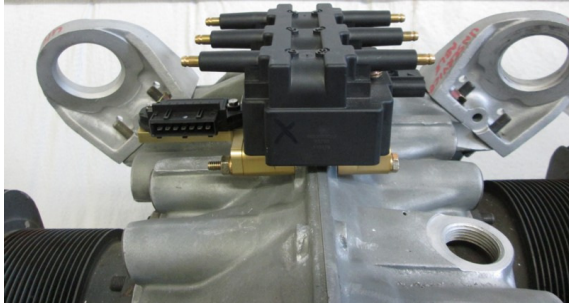

6 cylinder top case coil pack mount

Coil pack upper case through bolts torqued to 75 inch/ lbs.

Plug Wires, Boots and Terminals

We can supply MSD 8.5mm Superconductor wires, MSD plug/coil boots and MSD terminals to properly fit your coil packs. If you don't use these components, be sure to always use quality EMI/ Magnetic Suppression wires. **Never use solid core, non-suppression wires with SDS. You must always use resistor type plugs as well.** Keep the wires away from exhaust pipes or anything which could chaff through the insulation. Be sure to properly crimp the terminals as shown here: <https://www.youtube.com/watch?v=8kQDSlpKrCw> and see the file at the end of this manual. Make your longest wire first and add 1 inch in case the insulation pulls away some of the conductor with it when stripped. Lubricate the terminal and ID of boots with glycerin based hand sanitizer before trying to slide boot over terminal. We recommend you purchase MSD crimping tool PN 35051 or if you have a similar crimper, you can buy just the jaw set PN 2048. This does an excellent job.

If you are running twin coil packs, you should run a plug wire from each coil pack to each plug on a cylinder. This provides maximum redundancy in the event that one coil pack fails.

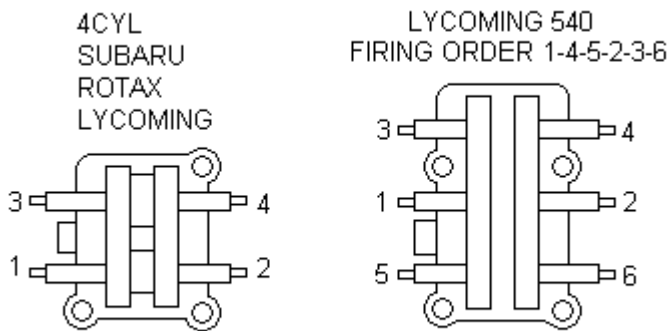

Plug Wire Connections to Coil Packs

SDS MAIN HARNESS IGNITION SIGNAL WIRE CONNECTIONS TO IGNITION DRIVER MODULE.

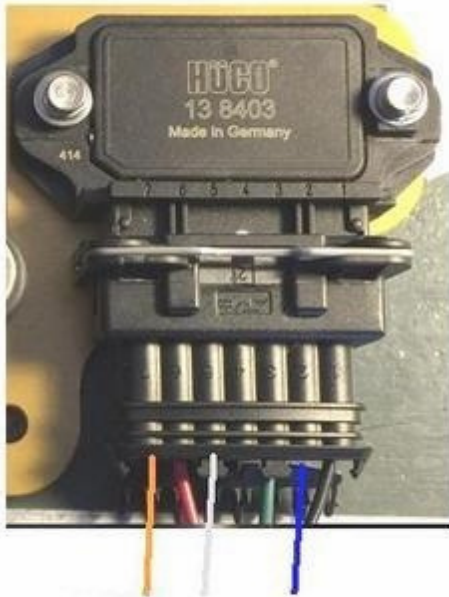

ORANGE PIN7
WHITE PIN5
BLUE PIN2

BE SURE TO GROUND THE MIDDLE BLACK WIRE COMING OUT OF THE MODULE PIN4.



WITH CONNECTOR LATCH UP, AFTER CRIMPING YOUR WIRES INTO TERMINAL, INSERT TERMINAL INTO CONNECTOR WITH CRIMP FOLDS DOWNWARD.

6 Cylinder Module Wiring

4 Cylinder coil pack wiring

4 CYLINDER COILPACK CONNECTOR



18 to 14mm Plug Adapters

We provide brass adapters to convert Lycoming 18mm plug threads over to 14mm in order to utilize less expensive automotive type plugs. We can also supply NGK or Denso plugs. Installation: Assembly: Install plugs into adapters and slide the copper washer over the adapter. Use only a thin stripe of anti-seize compound on the plug and adapter. Do not coat the threads.

1. Thread the spark plug into the adapter
2. Torque the assembly into the cylinder head using the PLUG hex to 19ft./lbs.
3. Torque the ADAPTER further to 25 ft./lbs.



Short reach



Long reach

Hall Effect Sensor and Mounts

We provide CNC'd Hall sensor mounts for 4 and 6 cylinder Lycomings using the 8 7/16 ID flywheel. These bolt to the front most case bolts on the right side of the case. Torque SS case nuts to 300 in/ lbs. Torque Hall mount bolts to 215 in/ lbs.

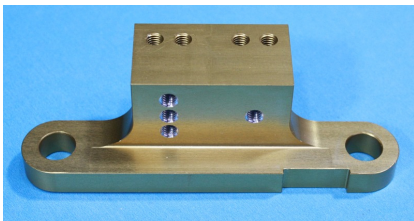

Narrow mount for engines with 3.25 inch bolt spacing

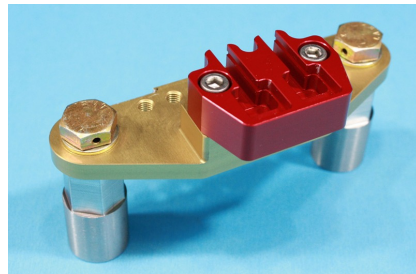

Wide mount for 3.50 inch spacing

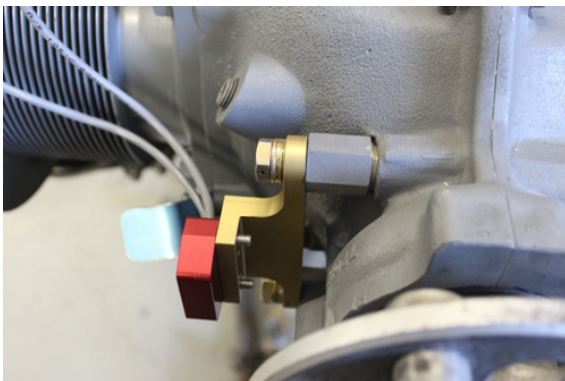

Narrow mount on case

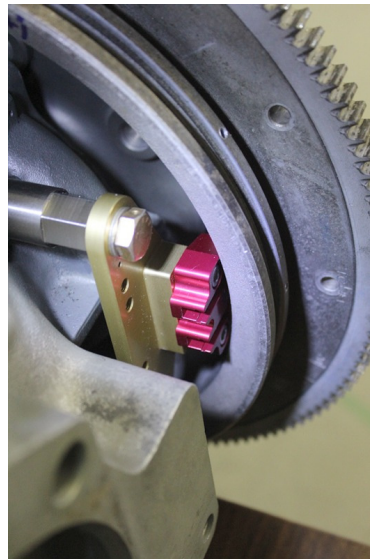

Wide mount on case with flywheel

The hall sensors are offered in a single or dual setup for single or dual ECUs. The mounts can accept either type. The mounts have multiple 10-32 threaded holes to attach cable protection shields if users are concerned about a thrown or broken belt damaging the Hall sensor cables.

MSD INSTALLATION INSTRUCTIONS

Dual Crimp Terminal Installation

ONLINE PRODUCT REGISTRATION: Register your MSD product online and you'll be entered in our monthly 8.5mm Super Conductor Spark Plug Wire give-away! Registering your product will help if there is ever a warranty issue with your product and helps the MSD R&D team create new products that you ask for! Go to www.msdpower.com/registration.

The terminals supplied feature a new Dual Crimp Terminal. The benefits of the new wire terminal is that the conductor has its own crimp to the terminal so it does not need to be bent over and pressed between the terminal and the sleeve of the plug wire. Following is a new crimp procedure for the Dual Crimp Terminal.

1. Strip approximately 1/4" of sleeving from the wire. When using the Mini-Stripper-Crimper, **do not** push the wire all the way into the tool to strip it. **Note:** Use extreme care not to damage the conductor.
2. Follow the standard instructions to crimp the terminal to the sleeve of the wire. **Do not** use the Mini-Crimper to crimp the conductor.
3. Position the conductor between the "conductor tabs" of the terminal. Using needle nose pliers, push the tabs towards each other so they firmly grip the conductor. Make sure the conductor does not squeeze out as you apply pressure to the tabs.

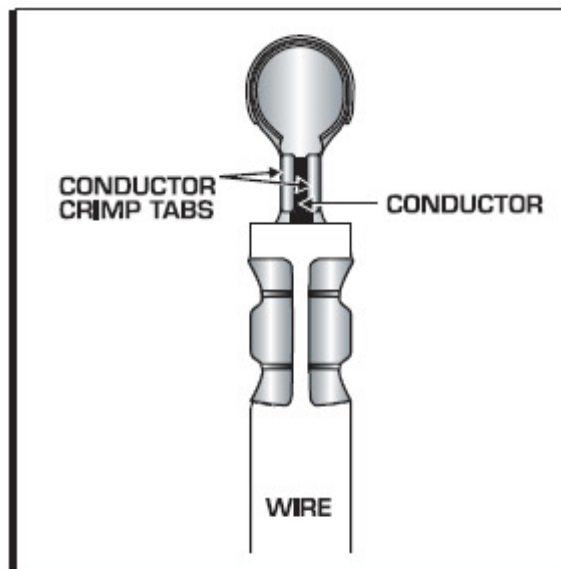
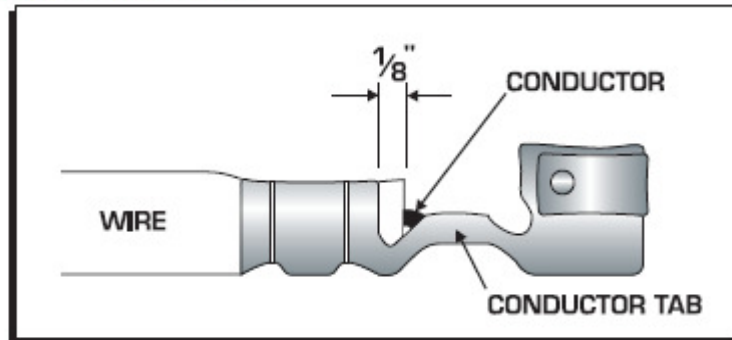

Be sure you push the plug and coil boots all the way down to engage the terminals fully with a "click". There should be about a 1/8 inch gap as shown in the photo below

