

EM-6 Aviation Installation and Tuning Manual for Version 33 Software.

Feb. 11 2024

Disclaimer

These products do not conform to any recognized set of standards or certifications for aviation applications.

This ECU is not waterproof and will not function as designed if moisture invades the enclosure or power/ ground connections are interrupted.

Failure of this unit may result in a complete loss of engine power.

Use of these products on amateur built/ experimental aircraft is at the discretion of the buyer who accepts full responsibility for any consequences resulting from its use. Since Racetech Inc. cannot control the installation, programming, application environment or use of its products, we accept no responsibility for damage, loss or personal injury resulting from the use of SDS products. By using SDS products, the user understands and accepts this.

If any user does not agree to this disclaimer, they may return the system/ parts in new condition for a full refund.

Please read the entire manual before attempting any hookup or running of the system.

Due to the technical nature of this system and depending on the engine type, we may include supplement manuals to cover different applications.

For tech help email Racetech/SDS at racetech1@telus.net or call 403-671-4015. When calling for help please let us know which system you have. See below for descriptions of different systems.

System Description

SDS EM-6 is available in 2 different models for aviation applications:

EM-6-D controls fuel injectors only.

EM-6-F controls fuel and ignition timing using coil packs or multiple ignition coils.

EM-6 is a microprocessor based, digital, programmable EFI system intended to control port type injectors and direct fire ignition coil packs. The EM-6 allows you to access all points in the engine operating map with the engine running and alter them according to your own specific needs utilizing a panel mounted LCD programmer.



Dual EM-6 ECU with Design1 programmer and SDS card data logger shown

Theory of Operation

Air temperature, CHT (or coolant temperature), manifold pressure, throttle position and rpm are all measured and taken into account by the EM-6 ECU which determines how often and how long the injectors remain open. The ECU generates a precise triggering pulse, which is fed to the injectors. The manifold pressure value multiplied by the rpm value determines the primary pulse width. Barometric compensation also corrects AFR with altitude behind the scenes, regardless of MAP.

Mechanical Section

Fuel System

In order for any EFI system to function properly, an adequate supply of fuel at the proper pressure must be present at the injectors. Problems are invariably blamed on the electronics when in fact 99% of all running problems are due to mechanical deficiencies. Most running problems are due to poor electrical connections or insufficient fuel supply/ pressure issues. **Failure to follow proper fuel system recommendations and layout can cause a partial or complete power loss.**

Any fuel system design must ensure that fuel feeds from the tanks to pump inlets at all times during normal flight conditions including uncoordinated flight at high bank angles.

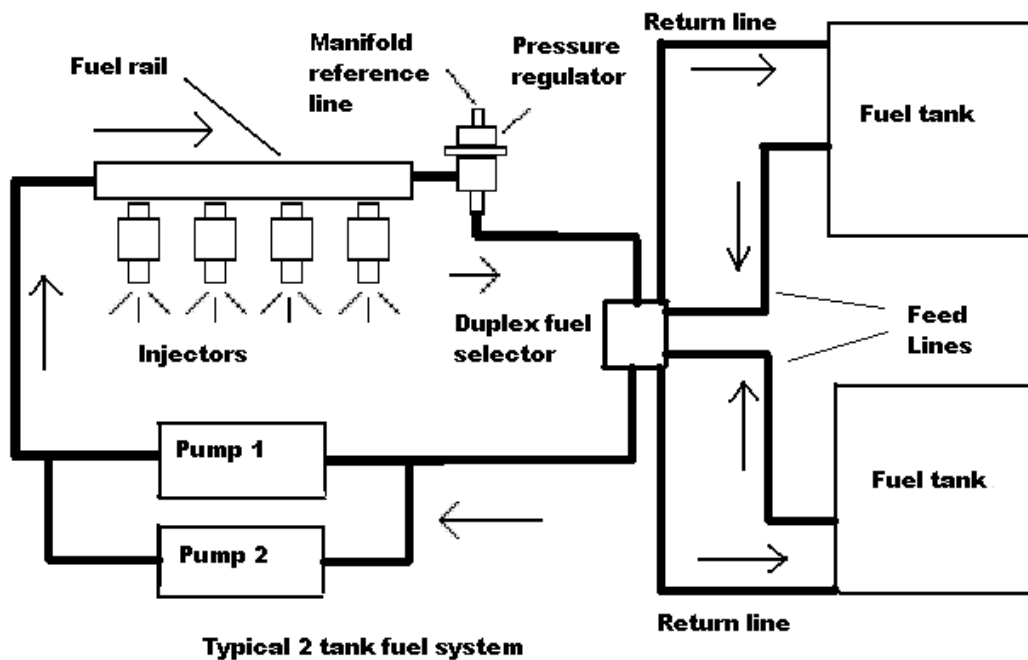

Injectors

We supply properly sized and matched injectors for your application. You should consult us if you plan to use different injectors for some reason. **Improperly sized or matched injectors can create running or tuning problems and our mapping recommendations may not be valid. Undersized injectors can cause engine damage in extreme cases.**

Fuel Pressure Regulator

We supply either an adjustable Borla regulator with AN-6 fuel fittings or a non-adjustable OEM type with O-ring sealed inlet and either barb outlet or 1/8 or 1/4 female NPT outlet fitting. We recommend the adjustable type have its **fuel pressure set to 45 psi** using the adjusting screw on the top of the regulator with the engine **not running**. Both regulator types have a MAP reference hose port for connection to intake manifold vacuum. **Using other unproven regulators is not recommended as failure can cause partial or complete power loss.** The adjustable regulator should be rigidly mounted to the firewall. The plug may be removed on the Borla regulator for tapping off fuel pressure. Threaded mounting holes are 1/4NF.

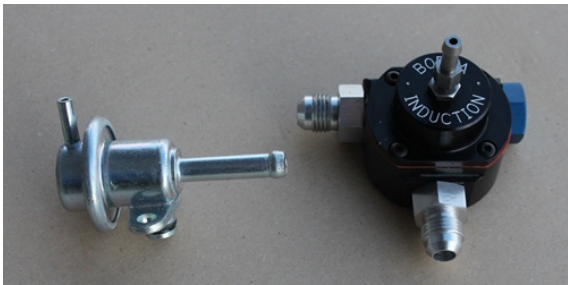

Non-adjustable and AN6 adjustable fuel pressure regulators

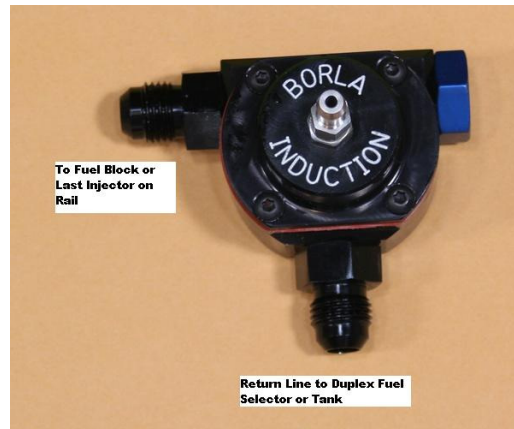

Fuel Pumps

We recommend using only the supplied/ recommended genuine Walbro/ TI pumps to ensure maximum reliability and safety with regards to re-priming in the event of a dry tank condition and to be sure they are properly matched to the hp of your engine. **The use of other brands is not recommended as failure can cause a partial or complete power loss condition.**

We can supply either a single pump or dual pumps mounted in a module to allow easier plumbing and mounting. **Be sure to follow the safety/ assembly instructions that come with the pump modules. Improper fitting assembly can cause line or pump blockage, leading to a partial or complete power loss.** Dual pumps should have separate power feeds, breakers and ground points for maximum redundancy. Fuse each pump with a 15 amp fuse or breaker. Nominal current draw is between 4.5 to 5.5 amps each at 14V, running at 45 psi pressure, depending on pump model.

Dual fuel pump module

On low wing aircraft, we recommend the pumps be mounted as low as possible on the floor, preferably parallel to the floor. **If you must mount the pumps vertically, mount them with the outlets facing UP, never down.** Inlet lines to the pumps should be 3/8 inch or AN6 with a minimum number of fittings used. We recommend not using any 90 degree fittings if possible on the pump inlets. Pump inlets should preferably be flooded by fuel at all times. It's normal that pumps can be rotated in the housing. They float on dual O-rings at each end of the frame.



Be aware that the black pipe plugs are not sealed or tight. Permatex 56521 can be used to seal the plugs.

Use caution tightening the nuts on the electrical terminal studs. Snug only. A number of people have snapped these off.

Never place fuel pumps close to any hot engine parts unless they have proper heat shielding/cooling.

We don't recommend mounting pumps close to the engine due to fuel heating concerns. Inside the cockpit is preferable.

Fuel Lines

Fuel lines from the fuel tanks to fuel selector and pumps may be rigid aluminum or steel tubing or Teflon lined, stainless steel braided flexible hoses. **Flexible hoses must have a conductive inner liner designed to limit static electricity buildup when carrying gasoline.**

Fuel lines between the airframe and engine must be flexible types of at least medium pressure rating (over 100 psi burst strength). **Never use rigid line between the airframe and engine which can lead to vibration breakages and fire hazard. Never place fuel lines close to any hot engine parts unless they have proper heat shielding.**

Most installations will route fuel from the pumps to a fuel block, then use separate braided hoses to connect to each injector boss. In this case, fuel from the pump enters on end of the block and return fuel exits the regulator on the other end of the block. Other installations will use a rail or loop type system where each injector is linked in series to each other. In this case, fuel from the pump enters the first injector and Tee fittings on each injector boss routes fuel to each remaining injector in turn. The regulator is placed after the last injector in the loop and fuel is returned to the selected tank through a Duplex fuel selector or header tank in the case of many shoulder or high wing aircraft.

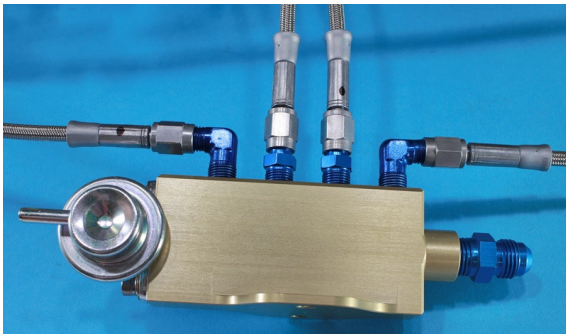

Fuel block with non-adjustable regulator

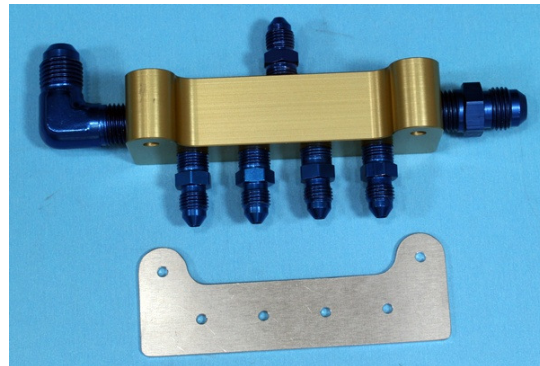

Fuel block and template for rear baffle mounting



Top engine mount fuel block



Return line using Earls Stat-o-seals

You must use fuel return lines with SDS EFI. Fuel return lines have little or no pressure present. Return fuel should enter the tank(s) at least 4 inches from where the fuel feed exits. Installation of return lines

into many tanks can be made in the access/ sender cover plate. Bulkhead fittings sealed with Earls Stat-o-Seals on both sides can make installation easier in many cases. We recommend 3/8 or AN-6 return fittings and lines.

Fuel Filters

We provide either a large single or 2 smaller filters (40 micron) to be mounted before the fuel pump module plus one small filter to be mounted between the pumps and fuel block, usually on the firewall. Note the arrow for flow direction. Ports are 1/4 NPT. Fittings supplied are AN6. Secure with the provided Adel clamps.



All fuel tanks should have screen type finger strainers on the fuel feed lines and/or 35-50 micron filters between the tanks and the pump inlets **Be sure to check the filters annually.**

On new build aircraft, construction debris can clog filters leading to pump damage or a loss of fuel flow which can cause a partial or complete power loss. Check at 10 hours initially.

We recommend turning the fuel pumps on and listen to the tone prior to engine cranking. Establish what the normal noise of the pumps is. Any increase in noise may mean that the fuel filters are clogging and restricting flow to the pumps. **Investigate before flight.**

On the pressure side of the pumps, always be sure that any filters used are rated to at least 100 psi. Use 3/8 lines and AN-6 fittings.

Gascolators

We don't recommend the use of gascolators with our EFI systems as they serve no useful purpose with a high pressure return type fuel system. If regulations require them, best to install them on the high pressure side between the pumps and injectors and use them as filters. **Be sure gascolators are rated to at least 100 psi.**

Fuel Selector

On any system using more than one fuel tank, we recommend using a Duplex selector which has a feed and return port for each tank. This ensures that returned fuel always goes to the selected tank which prevents pumping fuel overboard



Duplex fuel selector

Fuel Pump Cover

We supply a fuel pump plate to cover the hole where the old mechanical fuel pump was mounted. Seal this with RTV before bolting in place. If you have the engine apart, you can leave the fuel pump drive rod out (Lycoming), as it's not required with the electric EFI fuel pumps.

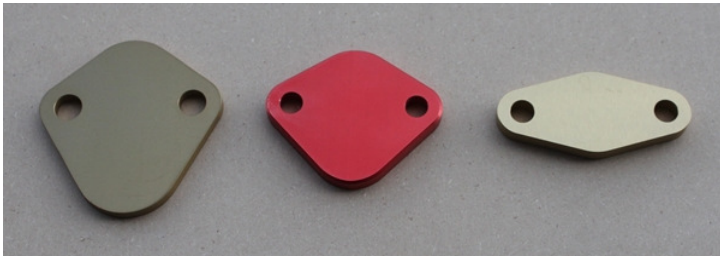

Lycoming, Jabiru and Rotax fuel pump covers
Fuel injector Mounting

Lycoming Parallel Valve Engines

On these, you are usually supplied with our dedicated injector mounting system which mounts the EFI injectors directly into the existing 1/8 NPT injector holes on the top of the heads. These use a special high strength stainless steel lower portion for low heat transfer and a floating 7075T6 bolting flange to hold the injector cap in place. We fit a stainless steel body injector for maximum temperature resistance.

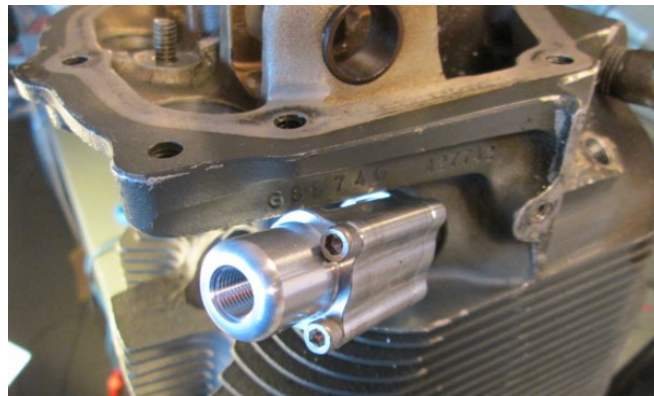
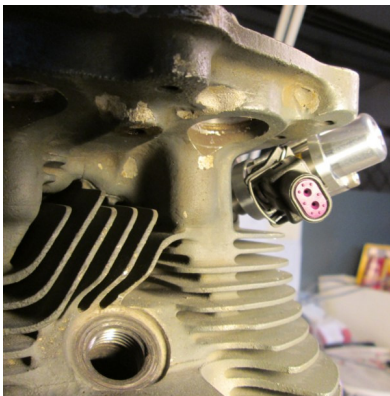

To mount these, remove the 1/8 NPT plugs from the injector ports (heat may be required). Slide the gold flange over the lower silver adapter from below. Apply Loctite 246 to the threads on the silver part and thread by hand into the injector port. Thread in until finger tight then tighten 1 ½ more turns. You should get about 4.5 turns of thread engagement. Be careful here, stripping the threads will be a very expensive exercise! Lubricate the lower injector O-ring and slide the injector into the adapter. Rotate the injector so that the electrical plug faces towards the spark plug. Lubricate the upper O-ring and slide the gold cap over the injector. Apply Loctite 246 on the two 8/32 Stainless socket head cap screws as shown above and tighten in place. **Only Loctite 246 is acceptable.**

We supply/ recommend –3 Stainless steel braided hoses to join the injector tops to the fuel blocks. The top cap is threaded 1/8 NPT female. Apply pipe sealant (not Teflon tape) sparingly to the fitting (either steel or aluminum) only, **making sure not to get sealant on the first thread.** Screw the fittings in at least a ½ turn past finger tight to get it orientated towards the fuel block fittings. **Never turn the fitting backwards once you start screwing it in.** Tighten the braided line swivel fitting in place being sure that they do not touch any other parts and are supported from vibration at least on one point. The upper gold parts should not rotate on the lower hex with hard hand pressure.

Lycoming Angle Valve Engines

We supply a different adapter for AV engines but the threaded silver base and gold ring are installed using the same procedure as above. Test fit the hex fitting and lower gold ring dry to check for clearance to the cylinder head. In some cases, you may have to relieve a small arc in the head for clearance with a Dremel tool. See photos below. **These parts cannot touch the head when tight.**

Once the base and ring are installed, lubricate the top and bottom injector O-rings and slide the injector into the lower base. We recommend you install the upper AN fittings into the gold top cap prior to installing the cap since you will not be able to tighten the fitting once the cap is installed. Use pipe sealant on the fitting threads as described above. Tighten and clock the fitting so it's perpendicular to the top cap flange holes as shown below before installing the top cap assembly to the injector.

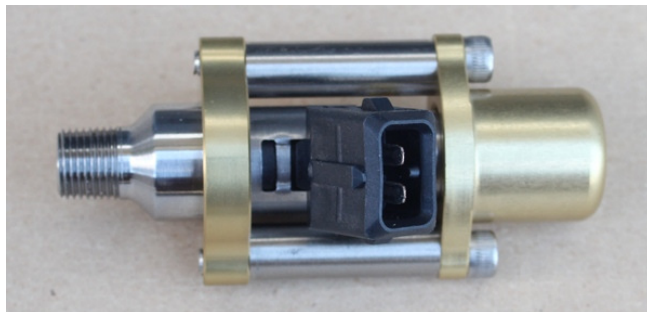

Apply Loctite 246 to the stainless cap screws and slide them through the tubular spacers. Alternately start to tighten the cap screws with an Allen wrench but stop just before the spacers start to touch the gold parts. Rotate the lower ring and top cap to the orientation shown below so you can get the Allen wrench on the cap screw. **Just before the cap screws are snug, squeeze the two spacers together with your fingers so that they engage the lower hex.** Tighten the cap screws fully. You can rotate the injector to orientate the connector as desired. The upper gold parts should not rotate on the lower hex with hard hand pressure.



Weld on Injector Bosses

Your kit might include either steel or aluminum base injector bosses which must be welded onto your induction tubes on some Lycoming, Continental or Jabiru engines. In the case of weld on types, the injectors should be mounted as near as possible to the intake ports, pointed towards the valve. Be sure when determining placement, that you can run fuel lines and fitting to the boss tops which won't be too close to exhaust pipes or any other obstructions. Be sure you'll be able to get the TIG torch all the way around the boss to do a good weld. Also be sure to check that you'll have cowling clearance for the boss and fuel fittings feeding it.

Weld-in injector boss

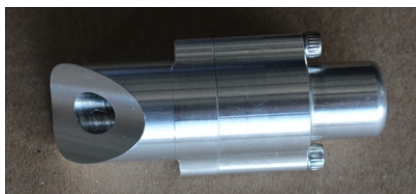

Make oval hole in induction tube



Mark the outside of the tube where the boss will be placed. Find the center of your mark and center punch it. Drill a 1/8 inch hole through the tube. Enlarge to 7/16 with a step drill. Take a 7/16 drill bit and put it straight through the hole. Lean the drill down slowly so an oval hole is cut into the tube to match your injector boss (45 degree angle). Line up the boss carefully with your hole (a cut off 7/16 bolt through the boss base, clamped in place, can help align it while tacking). Carefully tack the bosses in place, recheck fit and clearance. Remove the bolt before final welding. Final weld in place once you are satisfied everything is right.



Injector boss welded in place (Lycoming)

Throttle Body Mounting

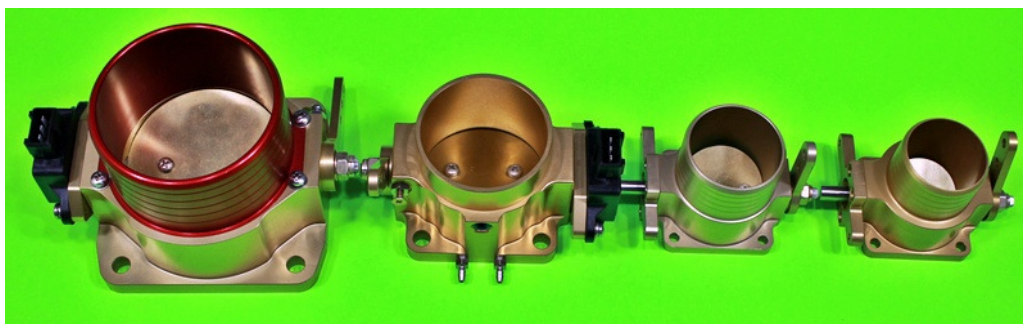

80, 60, 45 and 40mm throttle bodies

Lycoming Vertical Induction Engines

We supply a 60mm throttle body for these engines to fit in place of the carb or RSA-5 Bendix servo on O-320- O-540 engines. The TPS and throttle arm are already mounted. Use an ACS 2.5 inch aluminum flange (PN 10350-10) and supplied 2.5 inch silicone hose coupler to connect to air filters or the SDS FAB kit mount for Van's aircraft.

O-235 and O-290 engines use the 45mm throttle body.

Lycoming Horizontal Induction Engines

We supply either the 60mm throttle body if you have a sump designed for a carb or an RSA-5 servo, 80mm TB if your sump was designed for an RSA-10 servo. Again, the TPS and throttle arms are already mounted for you. The 60mm TB snout has a 2.5 inch snout and the 80mm TB has a 3.5 inch ID snout.

Continental O-200 Engines

These use the wide flange 45mm throttle body

Other engines

Engines below 120hp may use our 45mm TB in conjunction with a CNC'd adapter (Jabiru 2200/3300 engines) or bolted directly to a new fabricated or modified stock manifold. All TBs have O-ring sealed bases and provision for a TPS. Throttle arms are available for vertical, forward or aft facing applications. 10-32 Allen bolts are used to hold the TB to the manifold.

Throttle Position Sensor

If you ordered the TPS option, it will already be installed on your throttle body. Some engines run well without a TPS. The TPS offers quicker throttle response on most engines from low rpms. Wire color connections are as follows: Pin 1 orange, Pin 2 blue, Pin 3 white.

MAP Sensor

The MAP sensor may be mounted forward or aft of the firewall. **It should be mounted with the vacuum port facing down to prevent moisture from collecting inside. Never mount it with the port up.** Join the sensor port to intake manifold or TB ports with 5/32 vacuum hose. You may tee the MAP sensor hose with MP gauges and fuel pressure regulator if desired.

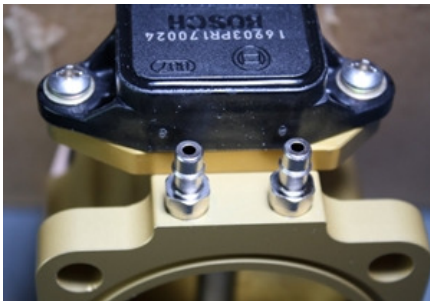
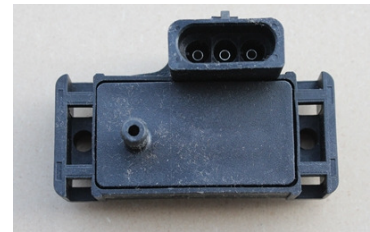

Throttle body fittings on 60 and 80mm models for connecting fuel pressure regulator and MAP sensor

Temperature Sensors



1/8 NPT, Bosch M 12 X 1.5mm and GM 3/8 NPT temp sensors

Air cooled engines usually use the SDS sensor provided. This has 1/8 NPT threads and is screwed into a primer or injector port as shown below. Some engines can use a bolt on adapter where no 1/8NPT holes are provided on the engine.



Other air cooled engines may use oil temperature. If this was your choice, you'd have a GM 3/8NPT, 1/8 NPT or Bosch 12 X 1.5mm sensor. Tap your sump accordingly.

SDS 1/8 NPT CHT sensor mounted in primer port hole. (Lycoming). This sensor is used for cold start and warmup enrichment only and will read much colder than dedicated CHT sensors embedded in the center of the head. 6 cylinder dual systems use 2 CHT sensors.

When routing the Engine Temp sensor cable to the sensor keep the cable away from spark plug wires by at least 1 inch, and never zip tie this cable to the spark plug wires. There is danger the plug wire could arc to to the temp cable damaging this input in the CPU



Air Temperature Sensor

On Lycoming installations, we supply 1/8 NPT sensors. The air temp sensor needs to see induction airflow. There are provisions on 60 and 80mm throttle bodies to mount these as below. 6 Cylinder dual systems use 2 air temp sensors. Other engines may use 3/8 NPT or Metric 12 X 1.5mm sensors. Tap accordingly. **When routing the Air Temp sensor cable to the sensor, keep the cable away from spark plug wires by at least 1 inch, and never zip tie this cable to the spark plug wires.**

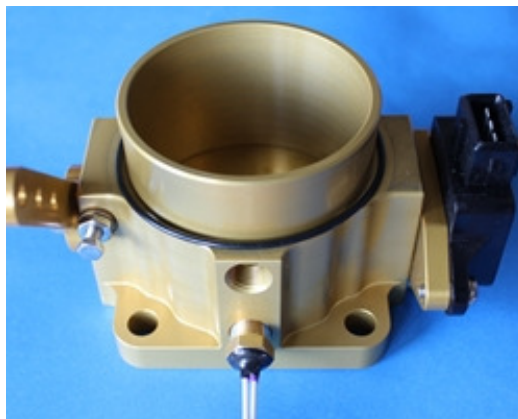

Lycoming Crankshaft Hall sensor mounting

We provide CNC'd Hall sensor mounts for 4 and 6 cylinder Lycomings using the 9.75" O.D. flywheel. The hall sensors are offered in a single or dual setup for single or dual ECUs. The mounts can accept either type. The mounts have multiple 10-32 threaded holes to attach cable protection shields if users are concerned about a thrown or broken belt damaging the Hall sensor cables.

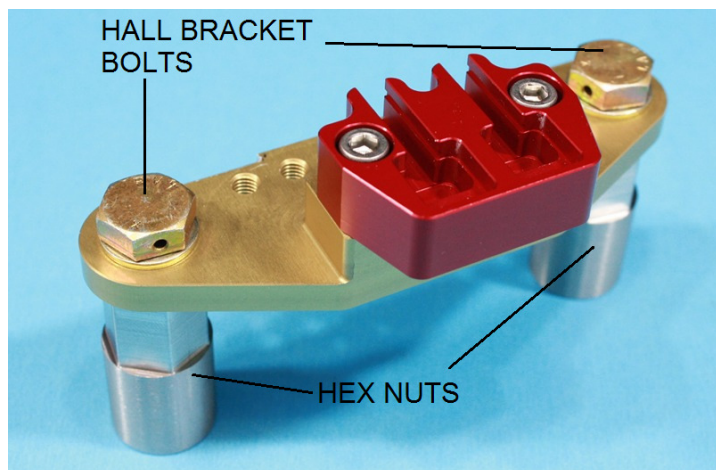

Wide mount for 3.50" spacing & dual Hall sensor.

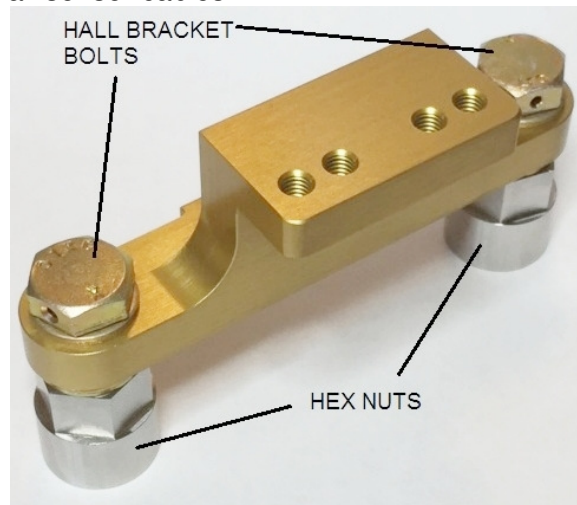

Narrow mount for 3.25" bolt spacing.

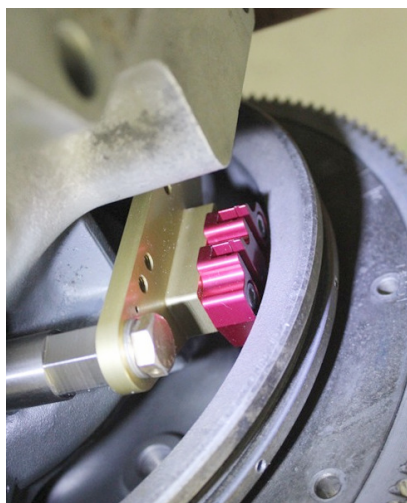

Wide 3.5 mounted rear view.

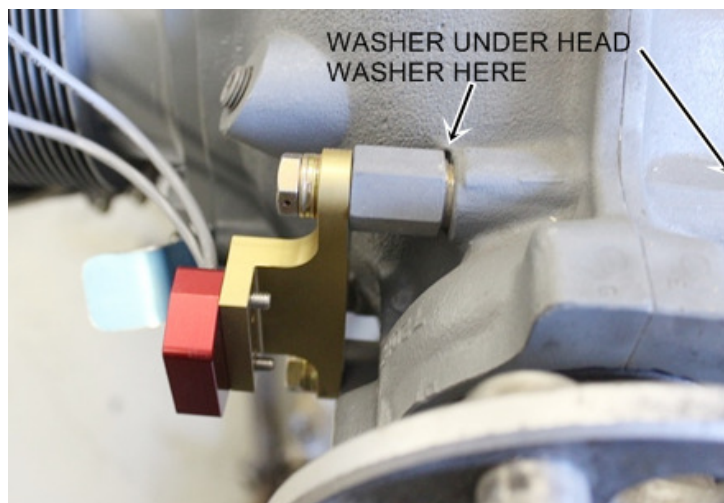

Narrow 3.25 mounted front view.

Case Bolts install: On 540 engines, the upper fastener is a stud instead of a bolt as on the 4 cylinder engines.

CNC'd mounts bolt to the front most Case Bolts on the right side of the case.

Steps to install the Case AN-6 bolts are as follows:

Step 1. Remove your front most case bolts, original nuts will not be used as new longer hex nuts are provided.

Step 2. Place one standard washer under the head of each Case Bolt. Factory washer is okay to use.

Step 3. From the case left side, pass the Case Bolts through the case so threads protrude on the case right side.

Step 4. Place a washer onto each case bolt.

Step 5. Thread case bolts into the Hex Nuts provided

Step 6. Snug case bolts for now, final torque should be done after clearance checking.

Hall Bracket Bolts: Place one washer onto each Hall Bracket Bolt. Pass Hall Bracket bolts through the gold Hall mount bracket, into the hex nuts provided. One issue only with the 3.25" bracket which can occur is the Hall Bracket Bolt collides with the Case Bolt inside the Hex Nut. If this occurs remove Hall

Bracket Bolts and place another washer under the Hall Bracket Bolts. You could also do a depth measurement from hex bolt surface down to the case bolt inside, and check against protrusion of bolt through gold bracket. Snug tighten for now torque can be done after clearance checking.

Clearance checking Hall Sensor Air Gap to Magnets and Flywheel inner surface

For Either the Single or Dual Hall sensors you need to have an air gap from the Hall Sensor edges to the pulley inner surface of about .025" to .040" See photo below. Use shim washers under the Gold Hall sensor bracket if you need to get the Hall sensor closer to the pulley to achieve proper gap. See photo.

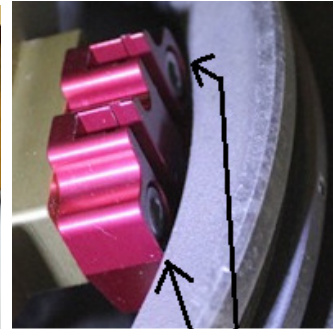

Clearance gap should be .025" to .040"

The wider Dual sensor vs Single Hall sensor ends up with a larger magnet to sensor air gap but this is okay since the magnets can still trigger the sensor as far away as .250" Single Hall with edge gap of .025" should end up with magnet-sensor gap of about .060". Dual Hall with edge gap of .025" should end up with magnet-sensor gap of about .090". Once correct gap is established, all bolts can be torqued to specs.

Torque Specs:

Case bolt/nut: 300 in-lbs.

Hall Bracket Bolts: 215 in-lbs.

Hall Sensor 10-32 Allen bolts: 25 in-lbs with blue Loctite on the threads, 30 in-lbs dry.

Hall Sensor mounting Rotax 912 engines This setup uses the "D" type or "F" type hall sensor and a machined magnet disc, which bolts to the rear of the crankshaft (slides over dynamo ring stub) and a machined Hall sensor mount which bolts to the upper left side of the engine. Magnets are already installed for you. Follow factory recommended torque procedures for the rear crankshaft nut.



Rotax hall sensor mount

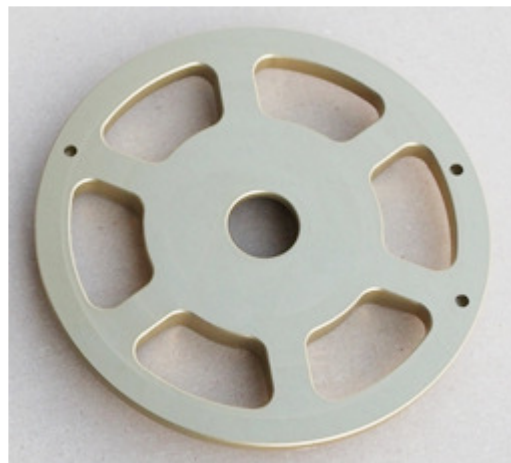

Rotax magnet disc

Hall Sensor mounting Jabiru 2200 and 3300 engines use a split magnet collar, which bolts over the crankshaft as shown below. The supplied Hall sensor mount bolts to the right front of the crankshaft seal plate as shown below.

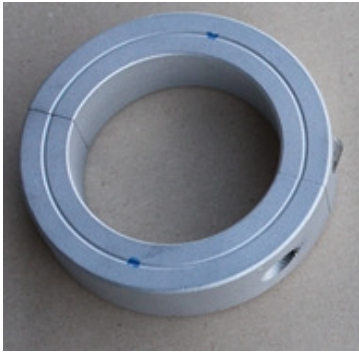

Jabiru magnet collar



Jabiru Hall Sensor mount

Set magnet air gap from the sensor to .050 - .080 inches by shimming the sensor or moving the collar as the case may be. Torque Hall Sensor 10-32 Allen bolts to 25 in-lbs with blue Loctite on the threads, 30 in-lbs dry.

Indexing of the magnet discs is not important on fuel-only systems. The ECU just needs a frequency. 4 cylinder engines will use 2 magnets 180 degrees apart, 6 cylinder engines have 3 magnets 120 degrees apart. These are called the trigger magnets.

Important, if your engine has fuel and spark control, your magnet disc will have an extra magnet mounted, inverted polarity from the rest. This is the synch magnet and identifies #1 cylinder to the ECU for spark control purposes. You'll also have a twin element Hall sensor instead of the single element one.

If you have spark control, you need to index the magnet disc so that, with the crank at TDC#1, the #1 trigger magnet (one of the equally spaced ones with the synch magnet closest to it) is around 80 degrees past the black squares on the Hall sensor, in the direction of crank rotation. See the diagrams in the F Supplemental Manual.

Lycoming Ignition Coilpack(s) Mounting

Most aviation systems will come with either 1 or 2 coilpacks. Dual ECU systems almost always have 2 coilpacks. Single ECU systems may have just 1 coilpack and use a conventional magneto as the 2nd ignition. The 4cyl ones have integral drive transistors, the 6cyl ones use an external drive module bolted to the coil mount with wiring connections in between. Both types may be engine mounted in any orientation. We offer several mounting brackets for Lycoming applications and flat type bases for firewall mounting.

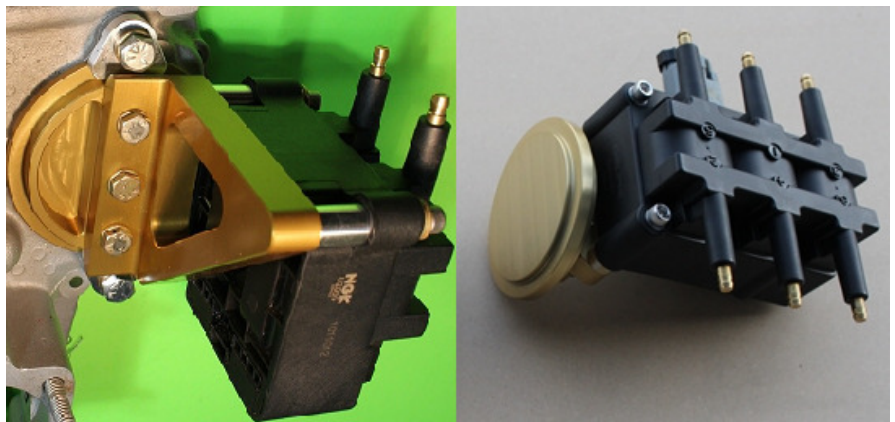

4 cylinder and 6 cylinder coilpacks with rear mag mounts

Lycoming, Important! If you're replacing the left magneto, be sure to remove the drive gear, coupler and bearing on some models from the case before installing the SDS mag covers or coil mounts. Use a thin layer of RTV on the mag covers before tightening the nuts. 6 cylinder engines require removal of the bearings, gears and cush drives. See separate exploded view document.

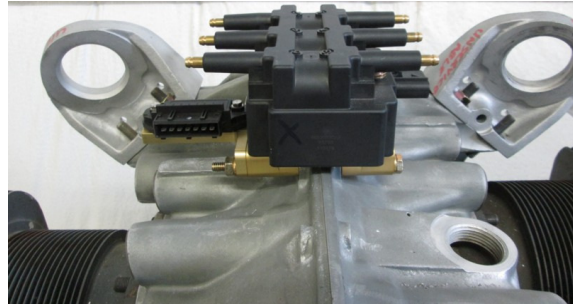
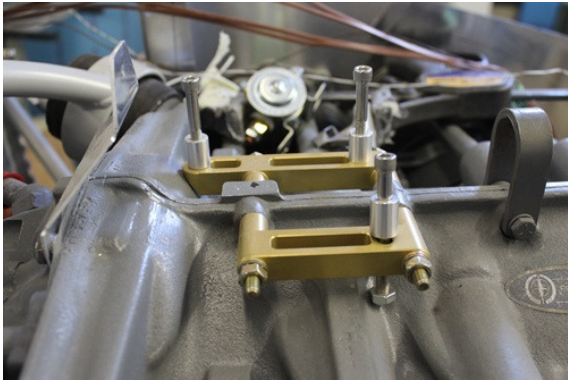

Lycoming 4 cylinder top case coilpack mount Lycoming 6 cylinder top case coilpack mount

Coil pack upper case through bolts torqued to 75 inch/ lbs.

For VW, Subaru, Rotax, or other, either engine mount or firewall mount whichever is easier. Keep coil pack at least 12 inches away from exhaust pipes or use heat shielding or air blast tube to keep the coil pack temperature down.

Spark Plug adapters 18 to 14mm

We provide brass adapters to convert Lycoming 18mm plug threads over to 14mm in order to utilize less expensive automotive type plugs. We also supply NGK or Denso plugs. Installation: Assembly: Install plugs into adapters and slide the copper washer over the adapter. Use only a thin stripe of anti-seize compound on the plug and adapter. Do not coat the threads.

Plug and adapter Installation:

1. Thread the spark plug into the adapter
2. Torque the assembly into the cylinder head using the PLUG hex to 19ft./lbs.
3. Torque the ADAPTER further to 25 ft./lbs.



Short reach



Long reach

Plug gap should be set at .032. Mounting of electronic enclosures, engine firing order & coilpack cylinder numbering and spark plug wires are covered in the Electrical section of this manual.

Electrical Section

ECU Mounting and Wiring Considerations

The ECU should be mounted in the passenger compartment in an area where it cannot get wet. If mounted horizontally, be sure the wiring harnesses have a drip loop to prevent water from running down them, into the ECU. **The ECU is not waterproof!** If possible, mounting the ECU with the connectors facing down gives the best protection against water ingress. **Never mount the ECU on top of the radio stack or within 3 inches of any DC motors or high pulsing current/ voltage wires or devices.** The ECU does not need any cooling or vibration isolation.

You should plan the ECU mounting to make wiring routing from it logically flow towards your firewall grommet holes. For best possible resistance to electrical noise, we prefer to have all ECU and other low level voltage/ current wires (thermocouples etc.) routed on one side of the firewall and all other airframe wires which carry higher voltages and current (alternator, starter, DC motors etc.) routed on the opposite side of the firewall and engine compartment. **Never tie wrap high voltage/current wires such as the starter, spark plug wires, alternator, strobes, radio transmitter, transponder, DC motors etc. to any of the ECU wiring.** A minimum 2 inch separation is preferred.

EM-6 ECU connectors

Dual ECU

The dual board ECU enclosure stacks 2 boards in a single box. The upper board, closest to the lid, is the Primary or “A” computer. The lower, closest to the mounting flange is the Backup or “B” computer. The optional PC data

logging function can only be connected to the “A” computer. On 4 cylinder models using the dual board ECU, there is no TPS, air temperature sensor, CHT sensor or mixture knob connected to the backup computer since these are non-critical to running the engine. 6 cylinder dual board models use two air temp and two CHT sensors, but share the TPS signal.

Dual board ECUs generally are used on engines with 2 spark plugs per cylinder. One ECU board drives the upper plugs and the other board drives the lower plugs at all times. A relay switch box is used to switch injector outputs between the 2 boards. The upper board is the Primary ECU, lower is the Backup.

Hole spacing for the ECU is 3.37 X 8.08 inches. Use the 10-32 stainless socket cap screws provided. Nut plates are recommended.

SDS Programmers

The EM-6 comes with either the Design1-6.25” rectangular, or Round 3-1/8” panel mount programmer which is used to adjust fuel and ignition timing values and also display engine sensor data on several gauge screens. Both programmer designs are Single ECU or Dual ECU capable as they have 2 DB9 ports on the rear to connect to the ECU be it Single or Dual ECU. The programmer can be toggled to either ECU as needed using the Prog key or toggle switch(3-1/8”).

Injector drive Main harness Hall Programmer



4 Cylinder

Switches and Breakers recommendations, Dual ECU

Item	Breakers Quantity	Breaker Amps	Switches Quantity	Switch included in system
Fuel Pumps	2	15	2, SPST	No
ECUs	2	2	Optional, SPST	No
Ignition Coils	2	10	2, SPST	No
Injectors	4	5	None	Not needed
Injector Relays	1	2	1, to ground SPST	Yes
Wideband Controller	1	5	None. Relay control through Pin 1 on 16 pin Molex	Not needed
Octane Select	0	None, switches ecu input to ground.	1, SPST. Pin 10 on 16 pin Molex, switch to ground.	No
SDS Card Logger	1	2	No	Not needed
Closed Loop Quick Enable/Disable Switch	0	None, switches ecu input to ground.	1, SPST, Pin 9 on 16 pin Molex, switch to ground.	No
Totals	13 Breakers Total***.		7 Switches Total ***.	

*** If Dual ECU using older round 3-1/8" programmer, add 1 more switch for ecu select, and if LOP operation will be used, add 1 more switch again to arrive at a total of 9 switches. Add one 2A breaker for the Fault LED light for a total of 14 Breakers.

The more modern Design1 6.25" wide programmer has its own ECU Pri/Bak select key and a LOP key on its keypad.

Several items above do not need switches, but can just turn on with the Main Buss power switch/contactactor.

Some of the above options may not be needed such as the Octane Switch or Closed Loop switch so this will change the total number of switches required.

Fuel pumps and ignition coils need dedicated switches to allow for individual function testing or "mag check".

4 Cylinder Single Power Bus Schematic

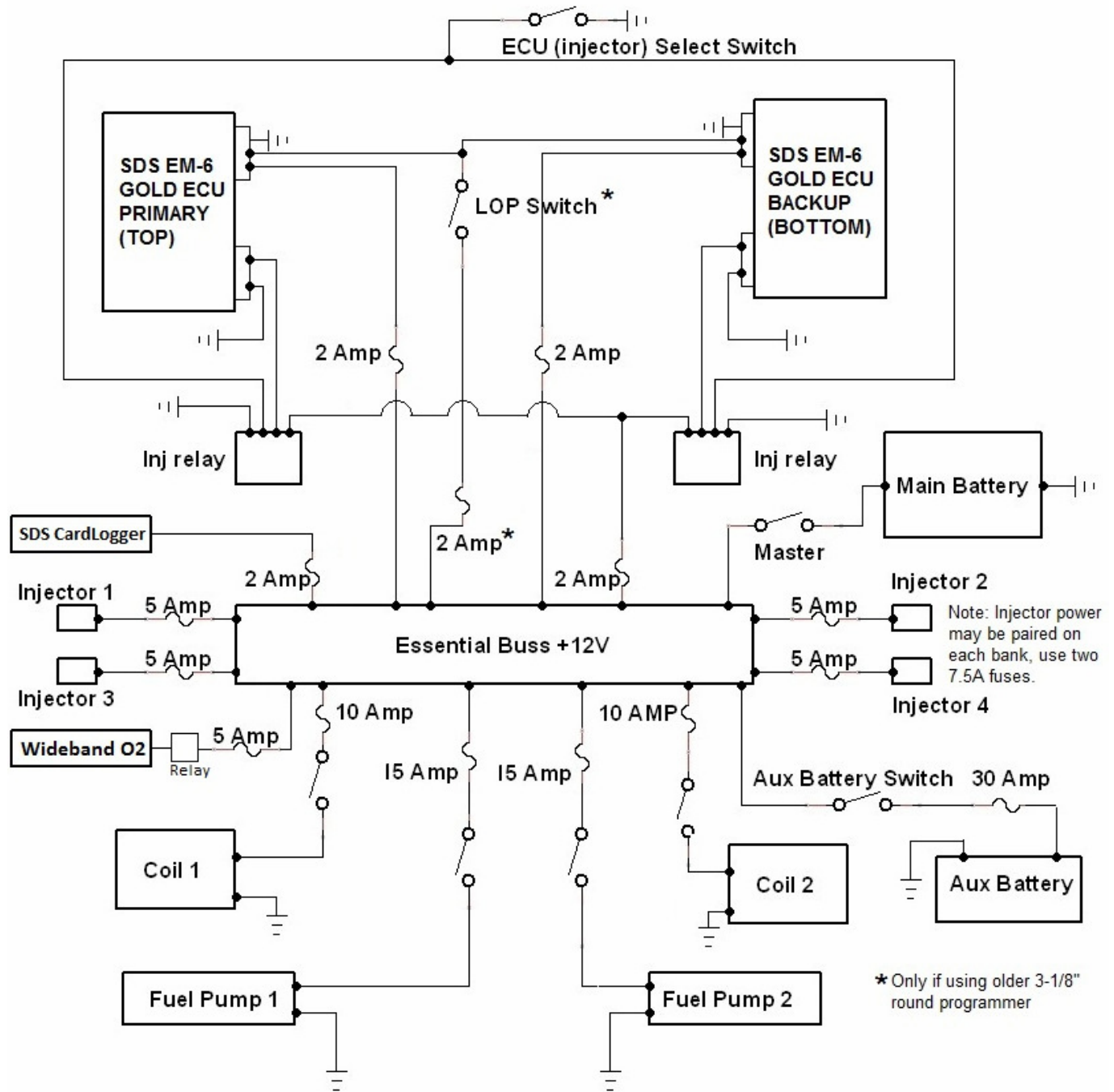

* LOP switch only needed if using 3-1/8" programmer. Design1 Rectangular programmer has a built in LOP Key on the keypad.

6 Cylinder Single Power Buss Switches and Breakers recommendations, Dual ECU

Item	Breakers Quantity	Breaker Amps	Switches Quantity	Switch included in system
Fuel Pumps	2	15	2, SPST	No
ECUs	2	2	Optional, SPST	No
Ignition Coils	2	10	2, SPST	No
Injectors	6	5	None	No
Injector Relay 6cyl	1	2	1, DPDT** On-Off-On (Center Off)	Yes
Wideband Controller	1	5	None. Relay control through Pin 1 on 16 pin Molex	Not needed
Octane Select	0	None, switches ecu input to ground.	1, SPST. Pin 10 on 16 pin Molex, switch to ground.	No
SDS Card Logger	1	2	No	Not needed
Closed Loop Quick Enable/ Disable Switch	0	None, switches ecu input to ground.	1, SPST, Pin 9 on 16 pin Molex, switch to ground.	No
Mixture Knob relay	1	2	None	Not needed
Totals for 6cyl Single bus.	16 Breakers Total.		7 Switches Total *	

* If Dual ECU using older round 3-1/8" programmer, add 1 more switch for ecu select, and if LOP operation will be used, add 1 more switch again to arrive at a total of 9 switches. Add one 2A breaker for the Fault LED light for a total of 14 Breakers.

** Injector relay switch: We supply a DPDT in event that customer wants to change to a Dual Power Buss type system in the future. The switch 2nd Pole could be left unused, or it could be used for indicator lights or fed to EFIS for switch position indication. If you change out this switch to a different type, make sure it has a center Off position!

The more modern Design1 6.25" wide programmer has its own ECU Pri/Bak select key and a LOP key on its keypad, so no need for a mechanical switch for these two functions..

Several items above do not need switches, but can just turn on with the Main Buss power switch/contactactor.

Fuel pumps and ignition coils need dedicated switches to allow for individual function testing or "mag check".

6 Cylinder Single Power Buss Schematic

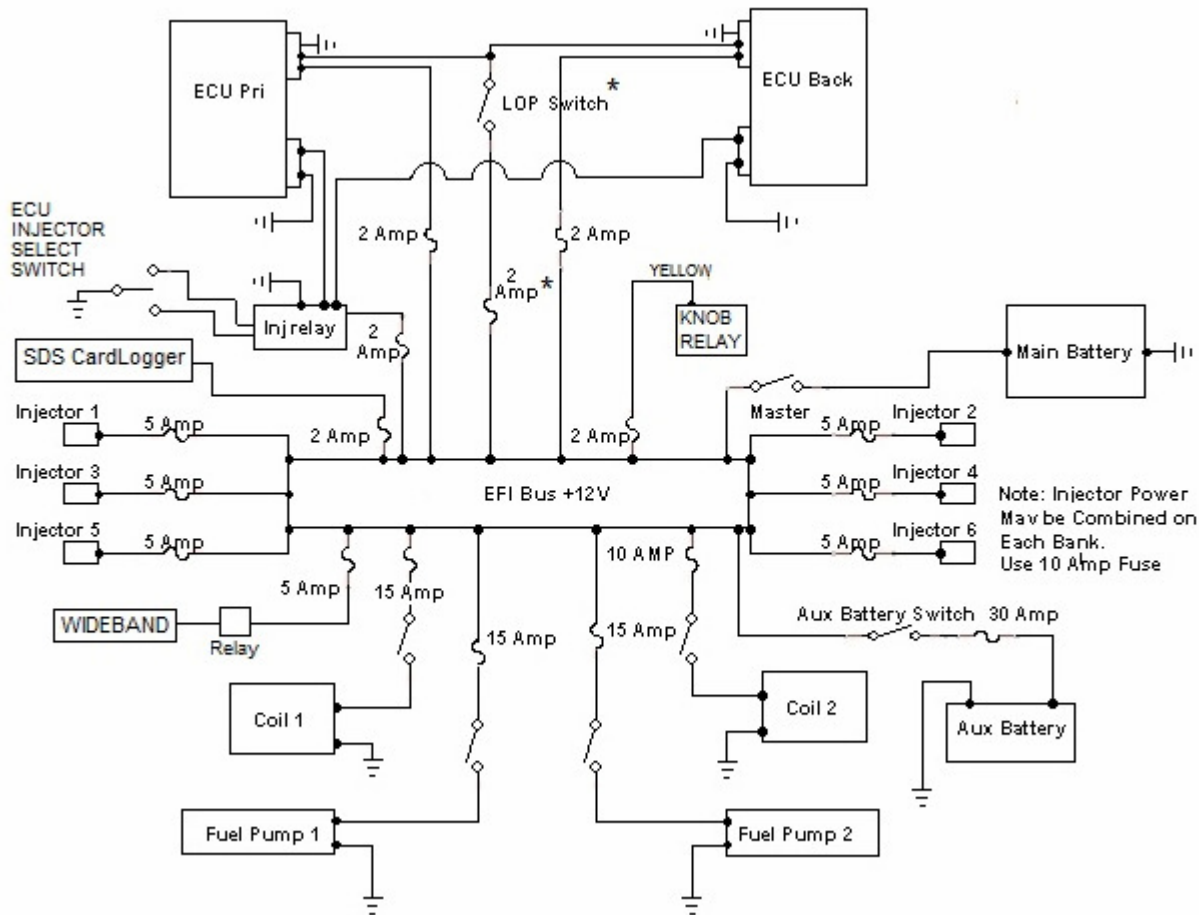

* LOP switch only needed if using 3-1/8" programmer. Design1 Rectangular programmer has a built in LOP Key on the keypad.

Please also read about the Dual Power Buss option since the manual makes reference to Single Power Buss and Dual Power Buss in some sections and being aware of this will reduce confusion. Dual Power Buss info comes next.

6 Cylinder Dual Power Buss*

Switches and Breakers recommendations, Dual ECU

Item	Breakers Quantity	Breaker Amps	Switches Quantity	Switch included in system
Fuel Pumps	2	15	2, SPST	No
ECUs	2	2	Optional, SPST	No
Ignition Coils	2	15	2, SPST	No
Injectors	6	5	None	No
Injector power Bus A	1	15	None	No
Injector power Bus B	1	15	None	No
Injector Relay 6cyl & Knob Relay	2	2	1, DPDT On-Off-On (Center Off)	Yes
Wideband Controller	1	5	None. Relay control through Pin 1 on 16 pin Molex	Not needed
Octane Select	0	None, switches ecu input to ground.	1, SPST. Pin 10 on 16 pin Molex, switch to ground.	No
SDS Card Logger	1	2	No	Not needed
Closed Loop Quick Enable/ Disable Switch	0	None, switches ecu input to ground.	1, SPST, Pin 9 on 16 pin Molex, switch to ground.	No
Totals for 6cyl Single bus.	18 Breakers Total.		7 Switches Total ***.	

*Dual Power Buss means that normally both busses are powered on all the time and both ECU's are running all the time when the engine is running. Both Busses each have their own alternator and battery. Power Buss A powers the Primary ECU & injectors 1,2,3 and Power Buss B powers the Backup ECU & injectors 4,5,6. Each Buss powers an ignition coil pack on systems doing ignition control. The Injector Relay Switch can redirect injector +12V power to either power bus when the switch is in PRI or BAK positions and also redirect all 6 injector signals to either the PRI or BAK ecu. Dual Buss design is an option when the airplane has dual high amperage alternators. If your 2nd alternator is lower amperage emergency backup type do not choose the Dual Buss method.

*** If Dual ECU using older round 3-1/8" programmer, add 1 more switch for ecu select, and if LOP operation will be used, add 1 more switch again to arrive at a total of 9 switches. Add 1 more 2A breaker for Fault LED for a total of 19 Breakers.

The more modern Design1 6.25" wide programmer has its own ECU Pri/Bak select key and a LOP key on its keypad.

Several items above do not need switches, but can just turn on with the Main Buss power switch/contacter.

Some of the above options may not be needed such as the Octane Switch or Closed Loop switch so this will change the total number of switches required. Fuel pumps and ignition coils need dedicated switches to allow for individual function testing or "mag check"

6 Cylinder Dual Power Buss Schematic

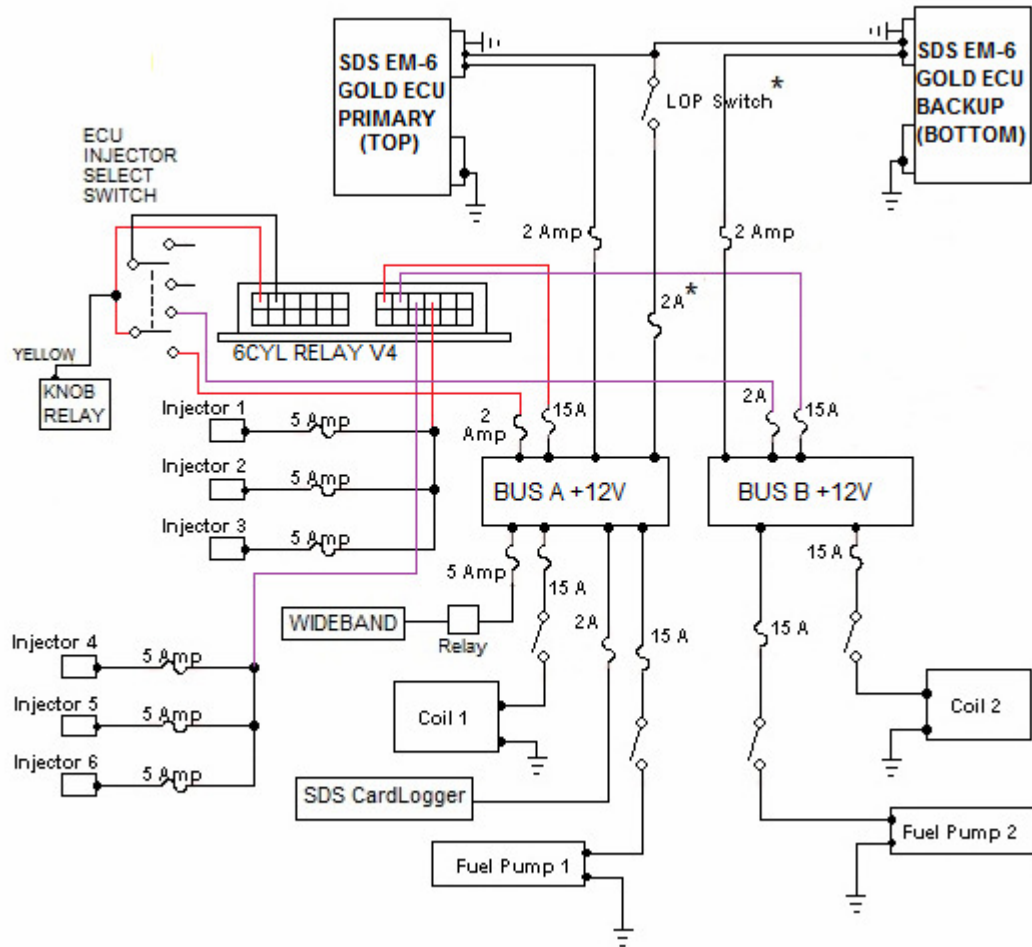

* LOP switch only needed if using 3-1/8" programmer. Design1 Rectangular programmer has a built in key on its keypad for LOP.

Backup Electrical Power Considerations

Electrical power is necessary to keep the ECU, fuel pump, coils and injectors running so it's important to think about having a backup power source available. In the case of Lycoming engines, a small backup alternator like the Monkworkz MZ-30L, B&C SD8, SD20 or BC410-H SD can be fitted to a vacuum pump pad. On other engines, a small second alternator could be fitted.

If you don't have a second alternator, you should have a small backup battery. Sizing would depend on your typical/ maximum distance between airports. Current draw of the pump, ECU, injectors and coils would be around 12 to 14 amps. A 12 amp/hour battery should give you 20- 30 minutes of flight time, just running the engine electrics. An 18 amp/hour one, around 45 minutes. The aim is to be able to sustain at least 10 volts to the electrics.

We've found the most reliable, simple and light way to get backup battery power to the engine electrics is a single 12 to 14 gauge wire running from the backup battery, through a 30 amp ATO fuse, to a heavy duty switch, to the main buss where all the engine electrics can receive power. Charge the backup battery every 30 days or close the switch during taxi, open before takeoff and load test annually.

Wiring connections are critical to proper ECU function. Make every connection with the thought that your life depends on each one. It does! Don't let wires dangle loose which can lead to eventual breakage. Support them every few inches for least mechanical loading on them.

Keep wires away from high heat sources and protect them from any possible chafing.

We like to see every individual wire, especially ground and power wires, be properly soldered or crimped (use the proper crimping tool!) AND a length of heat shrink tubing applied over connector and about 1 inch down the wire after for strain relief and backup wire retention. See following photos:

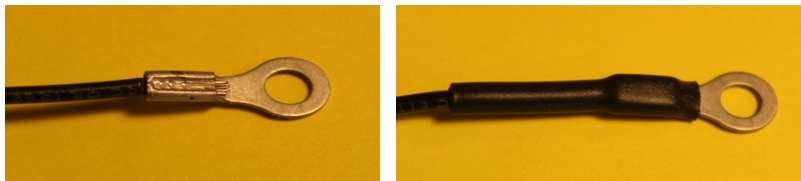

Battery Considerations

SDS EFI makes your engine electrically dependent so a battery in sound condition is paramount for proper operation. It needs to be able to maintain a minimum of 9 volts under cranking conditions. Low battery voltage may cause slow or uneven cranking, leading to overly advanced timing and possible kickbacks.

Flying with a marginal battery is just asking for trouble or getting stranded somewhere when the engine won't start. It's simply not worth the risk.

Low voltage affects all components with the system- ECU, fuel pumps, coils and injectors.

If your battery won't pass a load test- 200 amps for 30 seconds while maintaining 9V, replace it.

Tach Output Frequency

For setting up your engine monitor or steam type tachometer, 4 cylinder systems output 2 pulses per crank rev, 6 cylinder systems are 3 pulses per rev and 8 cylinder are 4 pulses per rev.

Yellow wire from DB25 outputs a 12V tach signal, green wire outputs a 5V tach signal

DB25 Main Harness connections for each wire & cable

Shown here has a 25 pin connector and connects the ECU to all the sensors. Right photo shows color coded main harnesses for dual ECU systems. Green for Primary, red for Backup. It is very likely you will purchase the system with an unterminated DB25 main harness so each wire/cable can be cut to length then terminals can be crimped onto each wire.



Recommended Crimp Tool for Main Harness terminal crimping



CrimpSupply.com P/N 18910 Designed for Weatherpack also works well for all terminals supplied. Crimp details below.

Tefzel general wire stripping info

See throughout DB25 harness section for specific cables recommended strip lengths.

Score the outer sheath insulation down to the braid without cutting through the braid.

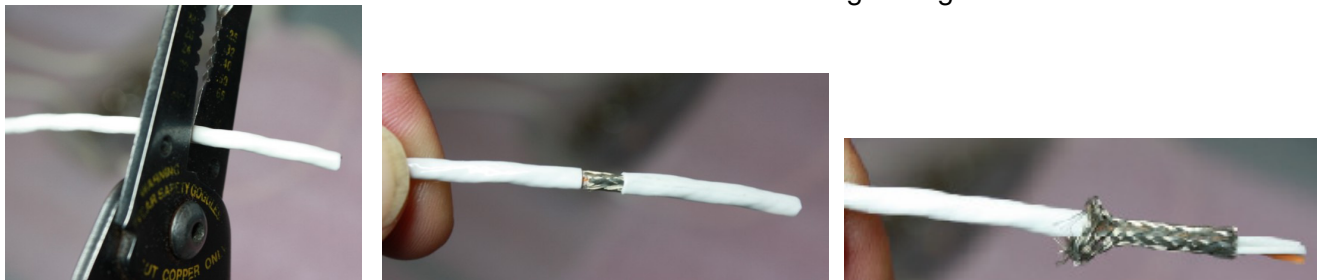

Pull the insulation forward. Compress braid downwards so it bunches up
Using sharp cutters, cut the braid all around the cable. Remove braid and strip conductor insulation

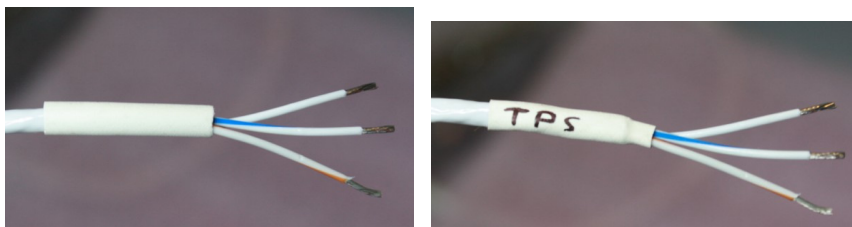

Apply heat shrink tubing so it extends over braid junction by about 3/16 inch. Shrink the tubing with a heat gun and label each cable.

DB25 Main harness Terminations

Black 20 gauge (computer ground). Ground to aircraft structure or ground strip close to the EM-6.
Important! Makes sure this connection is good and strain relief this wire also.

Red 20 gauge ECU power. Switched 12V. Fused with 2 Amp fuse.
Important! Makes sure this connection is good.

Knob cable Strip length for cable sheath about 1 inch.

Knob Cable Single ECU and 4cyl Dual ECU systems, Primary DB25 harness, crimp on mate n lok terminals use pos #2 on the crimp tool. Orange stripe wire goes into position 1 in the mate n lok connector housing. All white to position 2 middle. Blue stripe to position 3. If 4cyl dual ecu, the Backup DB25 harness does not connect to the knob so there will not be a knob cable on the backup harness.

Knob Cable Dual ECU 6cyl systems, Primary DB25 harness and also the Backup DB25 harness crimp on Mate-n-lok male terminals onto all 6 wires using #2 on the crimp tool.

Insert terminals as follows:

Orange stripe to Mate-n-lok pin1

All white to Mate-n-lok pin2

Blue stripe to Mate-n-lok pin3

Locate the Knob relay box which is a small black 2"x 1" x 0.5" enclosure with several wires and connectors. The Knob cables from Pri and Bak DB25 harnesses plug into the Knob relay box as marked on its connectors. The Knob relay box has a connector labeled Knob which you plug into the mixture knob potentiometer's mate-n-lok plug. Other connections to the Knob relay are covered below in the manual.

Knob relay box 6cyl Dual ECU only

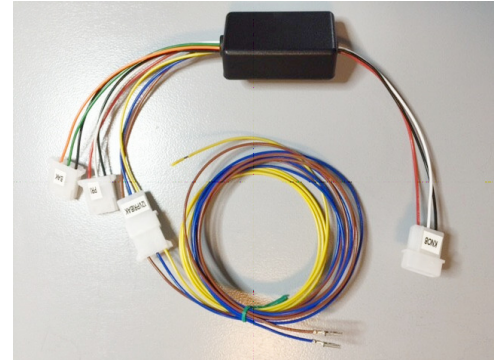

Green 20 gauge, pin 12: This supplies a 5V tach signal output to your tach or EIS.

Yellow 20 gauge, pin 22: This supplies a 12V tach signal output to your tach or EIS.

Tach signals are 2 pulses per crank rev on 4 cylinder engines, 3 pulses on 6 cylinder, 4 pulses on 8 cylinder.

Blue 20 gauge, pin 13 Main 25 pin D Sub: If you have the 3-1/8" programmer and are wanting to run LOP then this wire needs to go to your LOP switch. Your other switch wire needs to go to +12V. When the switch is turned On, the LOP will be activated, fuel will lean and timing advanced according to programmed values.

Gray 20 gauge and O2 sensor or Wideband meter hookup, pin 24

On the SDS main harness there is a single gray 20 gauge wire which you can connect to a wideband O2 sensor controller. Connection is required when you want to display the AFR (air/fuel ratio) in the SDS programmer or use Closed loop and Lean Warning functions in the SDS computer. The SDS can run without an O2 sensor if this is desired but a wideband should be used to accurately tune the system. Recommended Wideband O2 air/fuel sensor & controller is the AEM 30-0310.

Hookup to SDS is as follows:

Wideband Red to switched 12V through 5A breaker or fuse.

Wideband White to SDS main harness gray wire.

Wideband black to chassis ground

Wideband Brown connects to same place as SDS ECU pin 18 ground wire.

Mounting the O2 sensor, mount sensor minimum 12 inches from the exhaust port, and minimum 12 inches from exhaust tip (atmosphere). Sensor may overheat too close to port, and may pickup air when too close to exhaust tip. Sensor needs to be mounted at least 10 degrees above horizontal. See AEM installation manual for more details.

TPS Cable 4 Cylinder Dual ECU (throttle position sensor signal) On dual ECU 4cyl systems you will only connect the TPS to the Primary ECU while the backup ECU will not need any connection to the TPS. Strip about 1.5" of cable sheath, then strip length on each wire should be about 3/8" then fold the wire over to double its size for better crimp results. Squeeze crimper hard using position #2. To crimp the seal section of the terminal use position #1 on the crimp tool.

Be careful with these terminals going into the correct position, they are incredibly difficult to extract. If you make a mistake its better to cut/solder/heatshrink wires instead of attempting extraction.

Note connector orientation in photo and numbers, insert wires as follows:

Orange stripe into #1 position.

Blue stripe into #2 position.

All white into #3 position.

Zip tie the TPS cable as close as possible to the connector so that it does not flop around.

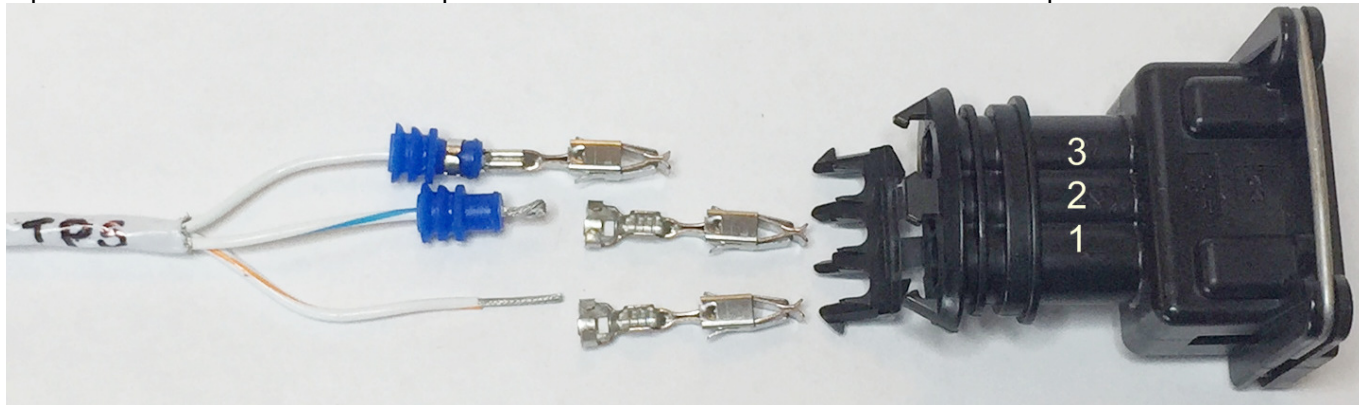

Photo showing strip length terminals and TPS connector.

TPS Cable 6 Cylinder Dual ECU: TPS cable from DB25 Primary harness,

Strip about 1.5" off the sheath. Locate the all white wire, strip about 3/16" from it. On the Backup DB25 main harness locate the 20ga orange wire, strip 3/16". Feed the Pri all white and Bak orange through a blue seal then line them up together. To lower stress on this smaller gauge white wire, lay both wires into the crimp section of the terminal with the white wire at the bottom and orange wire on top. Squeeze hard using #2 position of the crimper. As an option, you can crimp a short piece of wire into the TPS signal pin and make another connection which can be more easily disconnected with the white connectors and pins provided. To crimp the seal section of the terminal use position #5 first, then #1 on the crimp tool, no need to squeeze hard just close up the gap is good enough.

ORANGE FROM
BACKUP HARNESS

ALL-WHITE FROM PRI
HARNESS

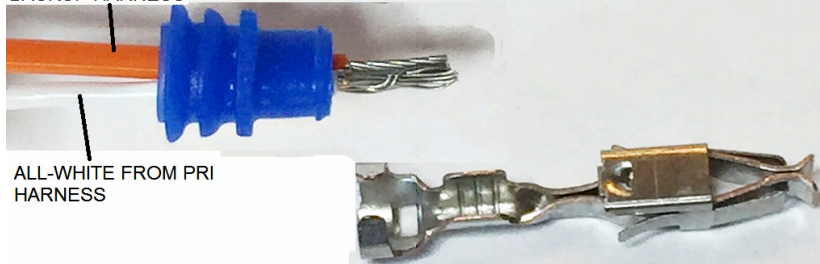

To lower stress on this smaller gauge white wire, lay both wires into the crimp section of the terminal with the white wire at the bottom and orange wire on top. Squeeze hard using #2 position of the crimper. As an option, you can crimp a short piece of wire into the TPS signal pin and make another connection which can be more easily disconnected with the white connectors and pins provided. To crimp the seal section of the terminal use position #5 first, then #1 on the crimp tool, no need to squeeze hard just close up the gap is good enough.

COIL cable, will be on the harness only on systems controlling ignition coil packs. 4cyl will have a 2 conductor cable, 6cyl a 3 conductor cable. 8cyl will have 4 separate 20 ga wires. These go to coilpack signal inputs to trigger spark in the coilpack. Fuel Only systems will not have this cable on the DB25 main harness.

COIL Cable 4cyl, Coil cable wire colors:

All white to #1 side of the coil pack. Blue stripe to other side of coil pack.

Strip length on wire should be 5/16" and then fold the wire over this helps the crimp hold better.

Crimp using the #3 crimp slot first then #2 to tighten up the crimp.

The Red wire on the coilpack connector needs to be run to your Coil Switch on the instrument panel. If 2nd coilpack then its Red wire to a 2nd Coil Switch on the instrument panel. Black wire to a grounding buss in the cockpit, do not ground on the engine due to heat and vibration reasons.

Photos of 4 Cylinder coilpack connector

4 CYLINDER COILPACK CONNECTOR



To insert terminals into this connector make sure the orange retainer lock piece is outward(unlocked). If it is inward(locked), then you cannot insert the terminals. It Orange retainer snaps out easily by prying on it with a small screwdriver. With connector latch up, terminals insert with crimp folds downward see photo. Once all terminals are installed then snap the orange retainer inward and then the terminals are locked in place. If you need to remove a wire/terminal then you can pry the orange piece outward until it comes off completely, then you can access the latches to pry upward with a small screwdriver to release the terminal. No special extraction tool is required to extract these terminals.

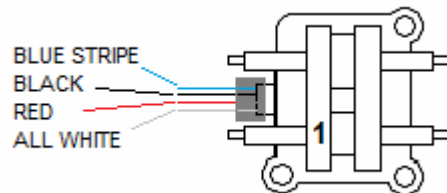

WITH CONNECTOR LATCH UP, AFTER CRIMPING YOUR WIRES INTO TERMINAL, INSERT TERMINAL INTO CONNECTOR WITH CRIMP FOLDS DOWNWARD.

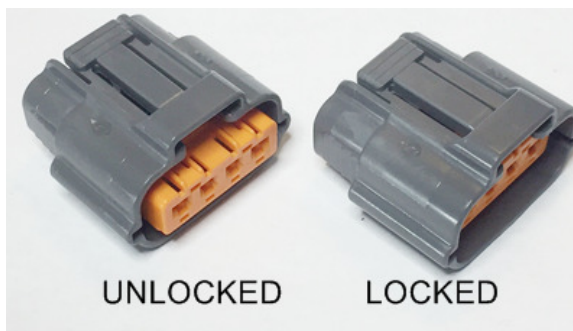

COIL cable 6 cyl, Coil cable connects to a black weather pack plug wire colors:
3 conductor cable wires connect to a 3 pin Weatherpack plug which is connected to the Ignition module shown in the photo. Crimp instructions are down below.

Crimping for Weathpack type terminals:

If 22ga strip length 5/16". If 22ga fold over the wire for best grip. Install the seal before you crimp!
If 20 gauge 1/4" strip. If 20ga no need to fold wire.



Crimp the wires using the #2 position on the crimp tool. Squeeze hard.

Orange stripe wire goes to Weatherpack A position & Orange wire going to ignition driver module.
All white wire goes to Weatherpack B position & White wire going to ignition driver module.
Blue stripe wire goes to Weatherpack C position & Blue wire going to ignition driver module.

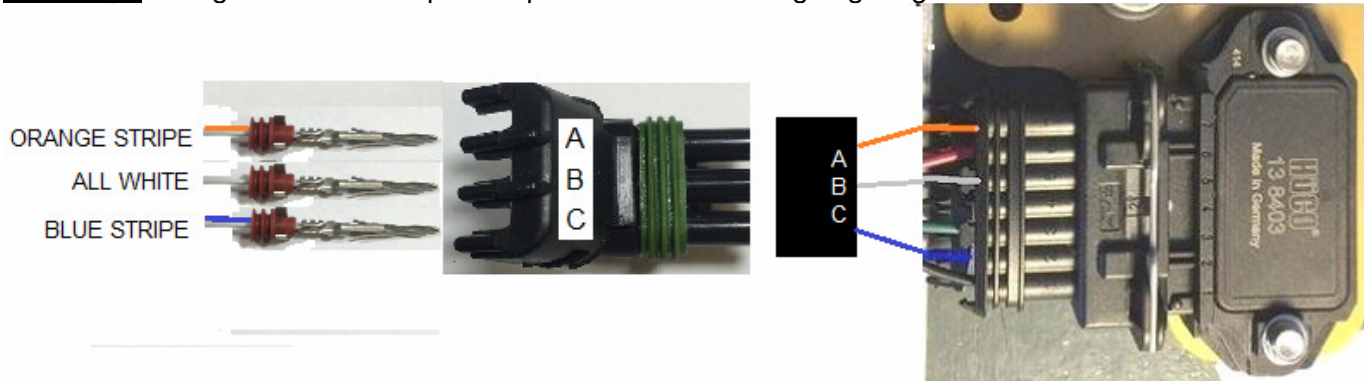

Insert all 3 crimped terminals into Black/green Weatherpack housing and close down the connector latch.

Important: Ignition module's middle pin4 long black wire run to interior grounding buss. Do not ground to the engine due to heat and vibration.

AT Cable connects to your Air temp sensor typically mounted in intake air stream plumbing or throttle body. See Crimping for Weatherpack terminals section above. No polarity for these wires.

ET or CHT Cable is for Engine Temp. Connects to your Engine temp sensor typically mounted into the cylinder head on air cooled engines, or engine coolant passage on water cooled engines. See Crimping for Weatherpack terminals section above. No polarity for these wires.

Future use wires on the DB25:

Purple and brown wires are for future use and not connected at this time.

***** End of DB25 Main Harness connections for each wire & cable *****

EM-6 16 position Molex connector

Ground wires. Important!

All ECU's. See image right, connect two black ground wires at left edge of connector to a grounding buss with no other wires shared at the same connection point.

Dual ECU there will be 4 ground wires total from the two connectors.

These should always be grounded even if the system is being used for ignition only(no injectors) which is done on rare occasions.

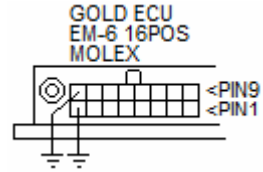

Octane Ignition Retard Switch and Closed Loop Enable

These are optional wires, yellow for Octane switch pin10, and white for Closed Loop Enable pin9. These wires can be inserted if these two options are required. Connect to switch with other switch terminal to ground. Option is active when the input is grounded by the switch. If you intend to run Closed Loop the switch on pin 9 is highly recommended because the Switch allows the pilot to quickly disable the Closed Loop feature in the event of an O2 sensor problem.

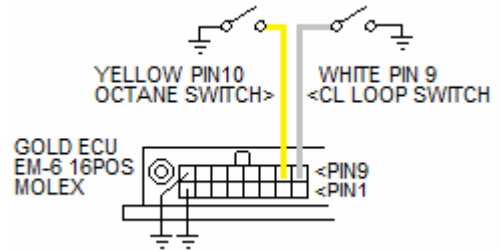

For Dual ECU 4 Cyl: White wire, connect from your switch to the Pri ECU only. Bak ECU does not need this signal since it should not run Closed Loop. Yellow wire, connect from your Octane switch to both the Pri and Bak ECU because each ECU is running ignition therefore both ECU's will need to retard timing.

For Dual ECU 6 Cyl: White wire, connect from your Closed Loop Switch to both Pri and Bak ECU's.

Yellow wire, connect from your Closed Loop Switch to both Pri and Bak ECU's.

Fault LED

Only supplied if the system comes with the 3-1/8 round programmer. The Design1 rectangular programmer has the Fault LED built in. On your panel you must insert the wiring through the front hole in your panel, then route wires to the ECU and 12V source. Panel mount Fault LED black wire gets inserted into pin 11 of the 16 pin molex plug. Red to +12V, 2A breaker. Panel hole size 1/4" diameter.

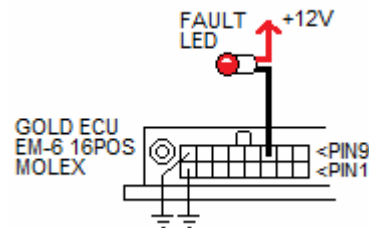

Brown 20 gauge, pin 2 white Molex: This supplies fuel flow data output (optionally enabled)

Purple20 gauge, pin 3 white Molex: Optional rpm switch, commonly used on VVT (Honda VTEC) systems.

Ground switched. Hookup schematic below:

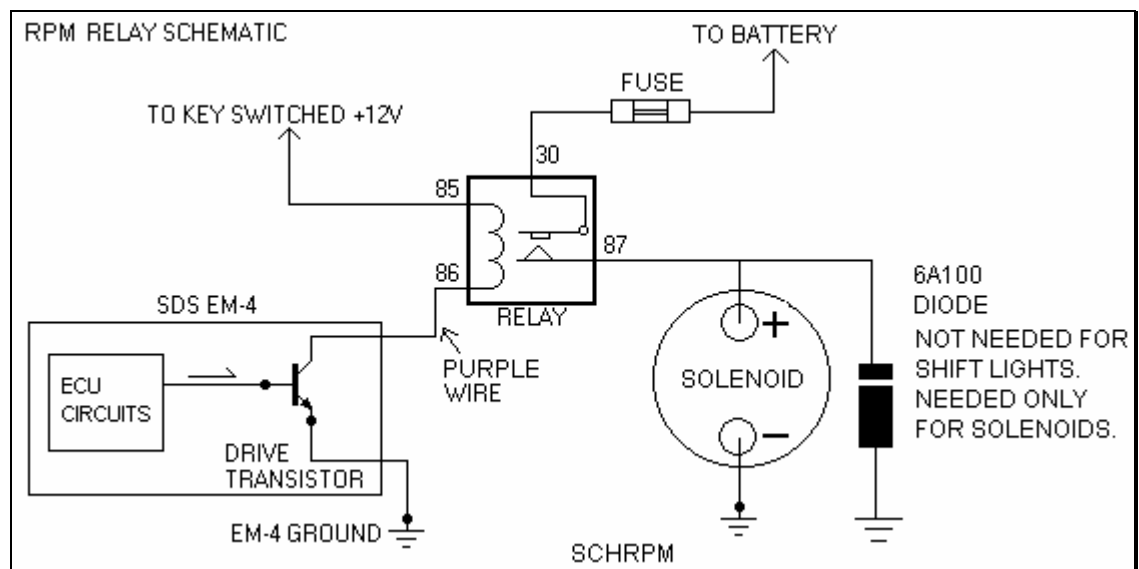

Orange 20 gauge, pin 1 White Molex: Optional fuel pump relay trigger wire. Ground switched. We generally don't recommend using this function on aviation systems. **Each fuel pump should have a separate switch, power wire, fuse/ breaker and ground wire (not grounded to the same terminal).**

Single ECU Wiring between the 16 pos Molex and Injector harness

(Dual ECU further down!)

These 20 gauge tefzel wires exit the ECU 16 pin molex connector are usually 6-1/2 to 10ft long. 4cyl colors are black, red, green and white, 6cyl wire colors are 2x black, 2x red, and 2x white. These wires connect the ECU injector outputs to the injector harness via black Weatherpack connectors. Cover these wires with your desired fireproof sleeve or conduit. Route through the firewall, bulkhead or baffling, but don't trim length until you check length of the Injector harnesses. Watch wire color and cylinder numbering to route to proper side of the engine. Below Dual ECU info there are instructions for crimping the Weatherpack connection to the injector harness wires.

4 Cyl Single ECU

Injector output wire colors 4 cyl Single ECU: Black to Cyl #1, Red to Cyl #2, Green to Cyl #3, White to Cyl #4

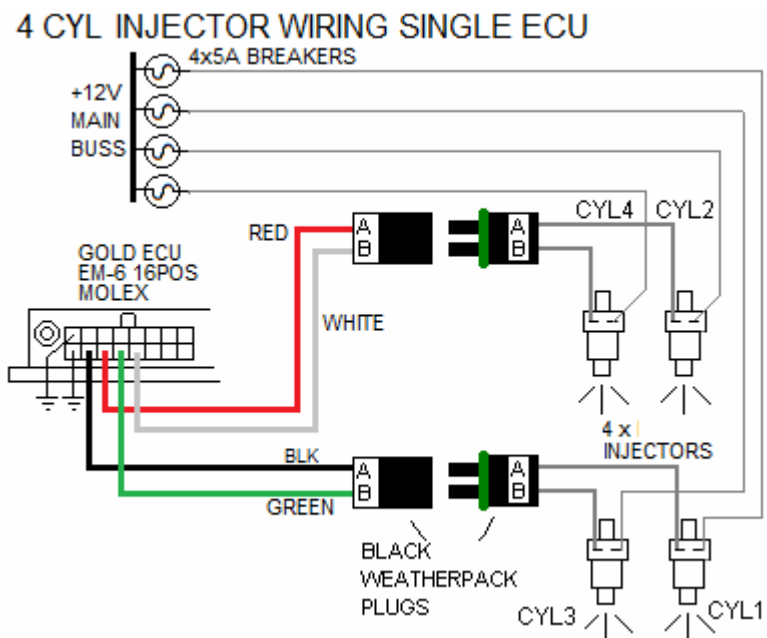

6 Cyl Single ECU

Injector output wire colors 6 Cyl Single ECU:
Blacks to Weatherpack A and Cyl #1 and #2.
Reds to Weatherpack B and Cyl #3 and #4.
Whites to Weatherpack C and Cyl #5 and #6.

It does not matter which black goes to Cyl #1 or Cyl #2., same for other wires. There are really only 3 outputs from the ECU so injectors are actually paired together. A Single ECU cannot do 6cyl individual cylinder trim, only a Dual ECU setup can do cylinder trim.

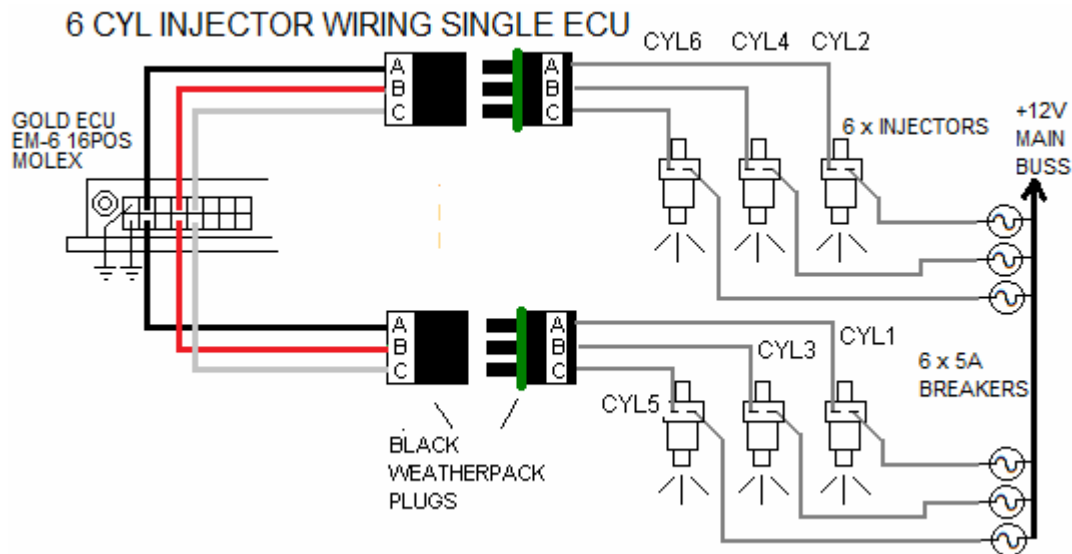

If you have a single ECU system skip ahead to Injector Harness section.

Dual ECU Injector Relay boxes 4cyl Power and Ground wires.

Injector relay boxes switch injector control between the two ECUs in a Dual ECU system. In the event one ecu fails or the engine runs rough the pilot can flip the Fuel ECU toggle switch and move the injectors onto the Backup ECU

Only power and ground need to be connected, since all other wiring connection for these relay boxes comes fully assembled, including connections to the Injector ECU switch and to each 16 pin Molex ECU connector. Wiring between the ECU and the Injector Relay boxes is only about 10 inches long ,so please mount these within about 8 inches of the ecu preferably beside the ecu side that has the 16 pin Molex connector, or above the ECU lid. Use 8-32 flat head screws. Mounting hole spacing is 2.56 X 1.03".

Wiring connections: If two relay boxes then the Red wires are already merged at the factory so the one long red wire needs **+12V via a 2A breaker** and can just be switched on with your master power switch. This does not need a dedicated switch.

Grounds ! Each relay box 12 position connector has a **black ground wire** that needs connection to a grounding buss. Grounds are the lower row, left side black wire of the connector.

In some 4cyl systems without cylinder fuel trim we may supply only one relay box and since injector circuits are paired in some cases, the switching task can be accomplished with only one relay box.

If your system has 2 relay boxes, they are both identical in design.

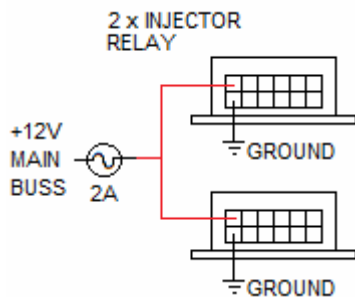
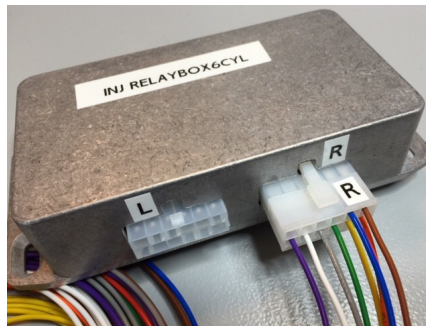
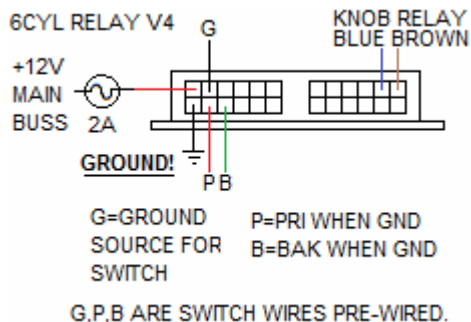

Photo of one 4cyl Injector relay box.

Operation: The relay switch input, when ungrounded, result is injectors are running from the Primary ECU, and when the switch is closed (switch input grounded), then injectors are running from the Backup ECU. In Primary ECU mode the relay box and relay inside it draw no current, it only draws current with switch in backup position. Failure mode scenario, if you, say, had a power failure to the relay upper left power wire, then the injectors would be on the Primary, engine would run, but you would not be able to switch injectors over to the Backup ECU because the relay inside cannot energize without a power source.

Dual ECU 6cyl Injector Relay Box, Ground, and wires from Knob relay.



Left connector Red wire needs **+12v via a 2A breaker** and can just be switched on with your master power switch. This does not need a dedicated switch. Left connector has one **Ground** wire connect to a grounding buss. Blue and Brown wires from Knob Relay harness need to be plugged into Right connector upper row right side. Use 8-32 flat head screws. Mounting hole spacing is 4.92 X 1.45".

Dual ECU Injector drive harness wiring to Injector harness

Dual systems use injector relays. Harnesses from the ECU Molex 16pos connector to injector relay box(es) come pre-built and plug right into the ECU's and Relay box(es).

Injector output 20ga colored wires exit the Injector Relay Box connector(s), are usually 6-1/2 to 10ft long and need to be routed to the engine bay where they will connect to the injector harness wires via black Weatherpack connectors. Cover these wires with your desired fireproof sleeve or conduit. Route wires through the firewall, bulkheads or baffling and use grommets. Also know the cylinder numbers on your engine and route colored wires to the proper bank of cylinders, numbering may be different from these diagrams. Don't trim wire length until you check length of the Injector harnesses. Weatherpack crimping info is below wiring diagrams. Wiring diagrams below will show wire colors and help you plan wire routing.

4cyl wire colors are black, red, green and white, 6cyl orange yellow, green gray white purple. You will also need to wire up your own breakers and run your own +12v supply wires out directly to each injector + terminal on each injector pigtail harness. Four wires on a 4cyl engine and 6 wires on 6cyl engine.

Injector output wire colors 4 cyl:
 Black to Cyl #1
 Red to Cyl #2
 Green to Cyl #3
 White to Cyl #4

Injector output wire colors 6 cyl:
 Orange to Cyl #1, Yellow to Cyl #2,
 Green to Cyl #3, Gray to Cyl #4,
 White to Cyl #5, Purple to Cyl #6

4 CYL INJECTOR WIRING DUAL ECU

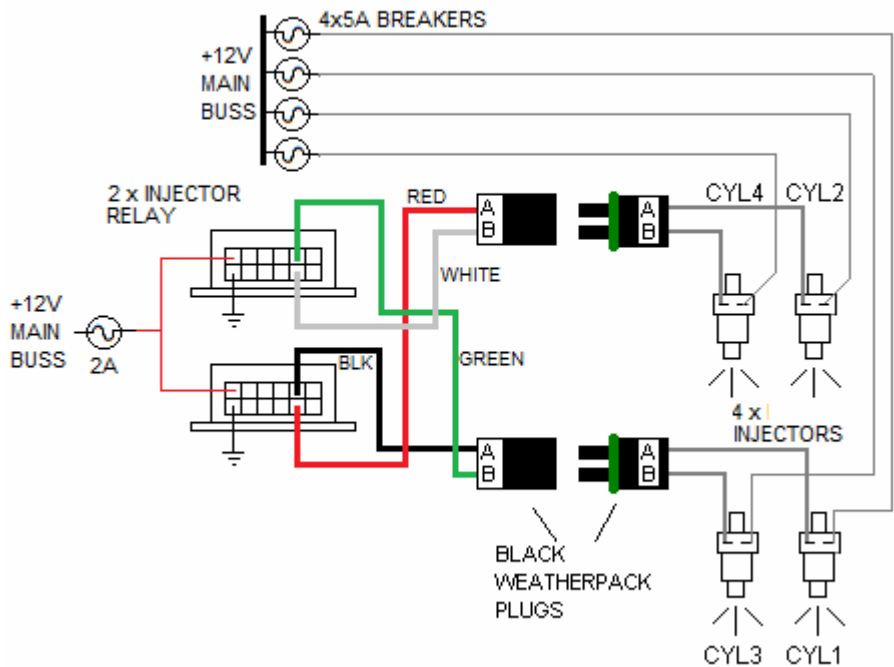

6 CYL INJECTOR WIRING SINGLE POWER BUSS DUAL ECU

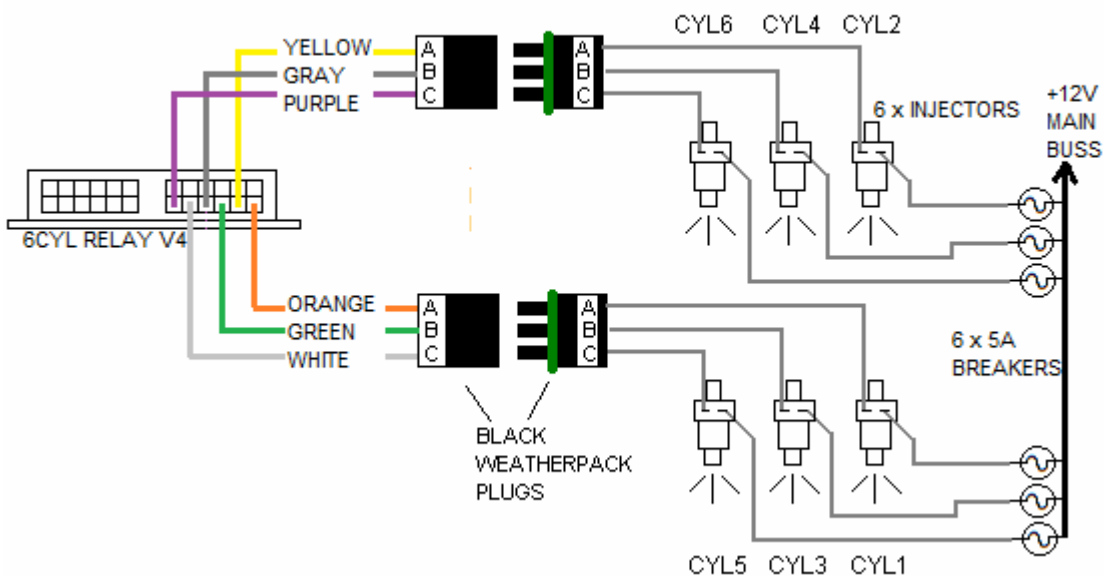

6 CYL INJECTOR WIRING DUAL POWER BUSS DUAL ECU

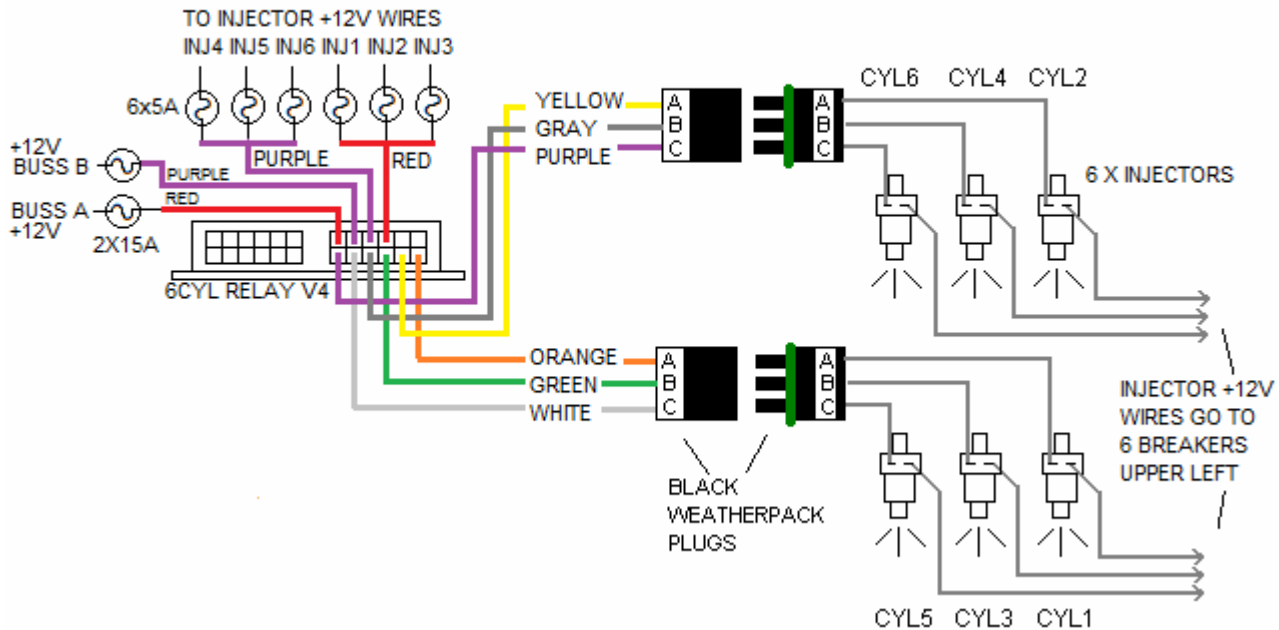

Injector Harness

Injector output wires need Female weather pack terminals crimped on. Below left side of photo is a 3 conductor connector used on each bank of cylinders on a 6cyl engine. 4 cylinder engines use 2 x 2 conductor Weatherpack plugs and look similar. Strip length is about 3/16 to 1/4" for wires. Don't forget to install the red seals before you crimp the terminal. Right side of photo shows Male terminals and injector harness wires will need to be crimped into these. Use position #2 on the crimp tool squeeze hard. Pull on the wire to make sure the crimp is good and the wire does not pull out using about 10lbs pull force.

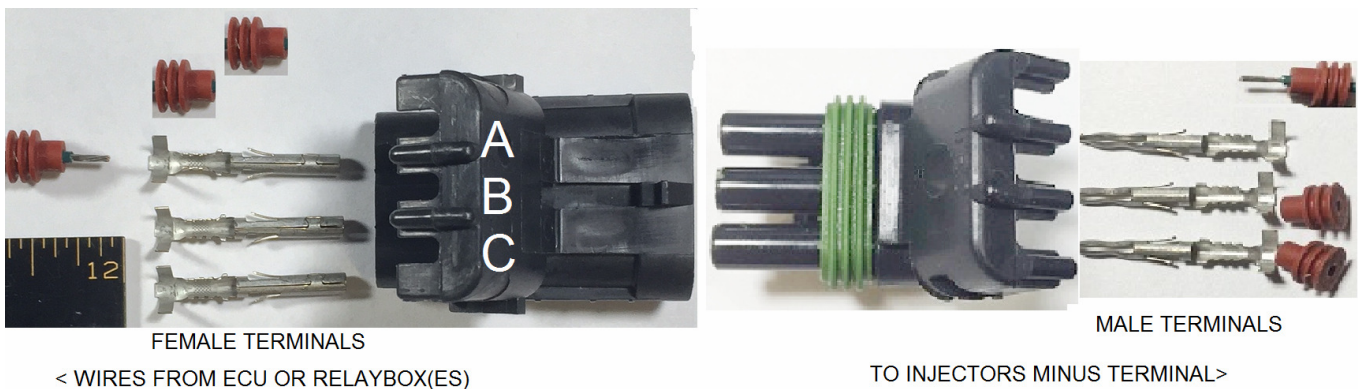

Look through the injector harness wires. Pick the longer length ones for the cylinders farthest from your Weatherpack plug connection point.

Injectors do not have polarity so either terminal on the injector can be +12V or ECU output(minus).

One wire from each injector goes to a weatherpack connector, and the other wire from each injector must go to 12V supply via a 5A breaker. You will need to lengthen the injector wires destined for +12V supply connectors and extra wire are not supplied for this so splice long run wires back to your breaker panel & +12V.

Right, Injector Harness pigtailed



6 Cylinder Dual ECU Only Mixture Knob Relay connections

If you have a Single Board ECU skip this section.

The single mixture knob affects either or both ECUs via a special Knob Relay box as shown in the photos. Knob relay to DB25 harness connections were covered above in this manual. Most connections are simple plug in, but a few need to be connected during installation, **Yellow, Blue and Brown** wires which exit a 3 wire Mate-N-Lok plug connected to the Knob real box. Photo right shows Knob Relay Box.

Photo below Knob Relay Box

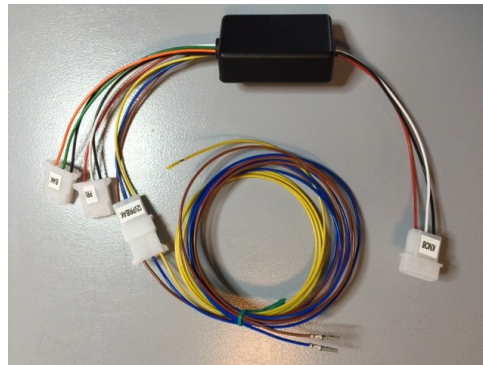

Blue and Brown wires and connect to gray Injector relay box.

Terminals are pre-crimped onto the ends of the blue and brown wires, insert into the R connector that goes into the Injector relay box Right side. See photo R.

Insert Brown upper right corner, blue beside. Terminal orientation, latch wings should be on sides and crimp folds visible on top. Should click when inserted all the way, compare depth of terminal with other adjacent terminals already installed.

6 Cyl Dual ECU Single Power Buss:

Knob relaybox **Yellow**: Connect to main buss on 2A breaker, can turn on with master so no switch needed. Repeat info: Injector Relay box red to 2A breaker, show again just for clarity. Skip over Dual power buss section!

If 6cyl Dual with **Dual Power Buss**: Knob relaybox **Yellow**: Connect to the Injector Pri/Normal/Bak switch. You will need to merge and crimp together this Yellow wire together with the Red wire from the Injector Relay Box into a .250" spade terminal which connects to the Pri/Norm/Bak switch middle red wire. See diagram below.

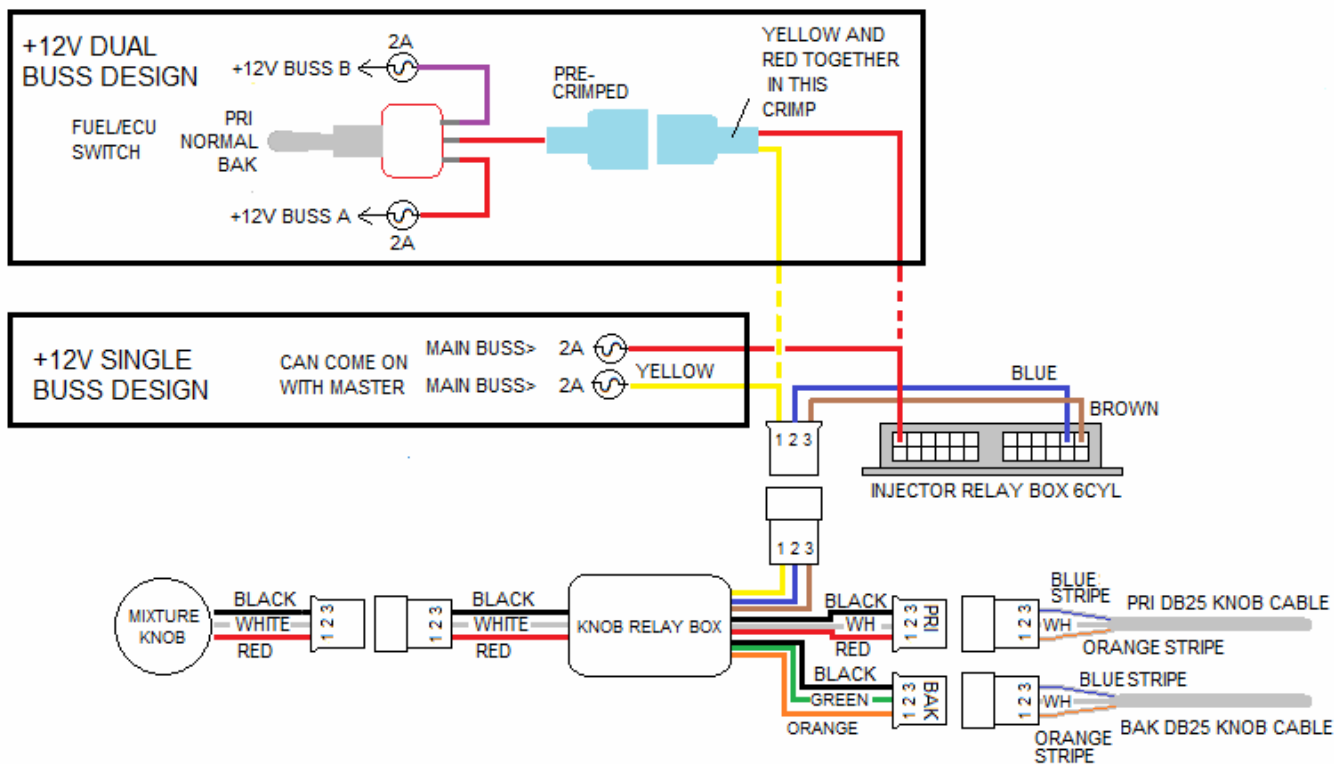

6 Cyl Dual ECU Dual Power Buss only connections

Photo right, closeup of Injector Relay Switch

Foreground 3 switch wires Purple To +12V Buss, 2A breaker. Middle Red to Knob Relay and Injector Relay +12V wires. Bottom red in photo to +12V Buss A, 2A breaker.

Background prewired connections to Injector Relay Box Left connector.

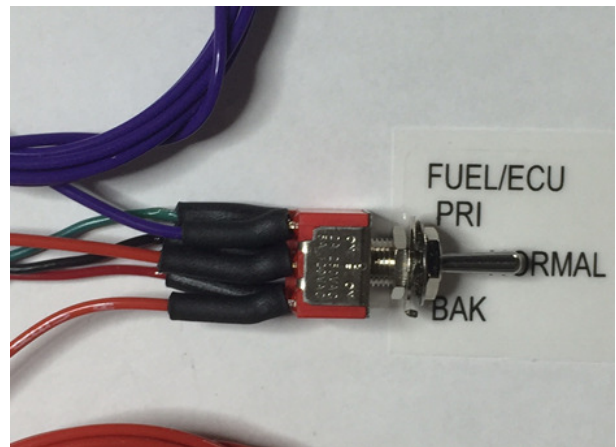

Prior to mid 2022 SPDT switches were used and after that, DPDT switches were used in the event a customer wanted to change to a DUAL +12V power Buss design. If ordering a system it is best to indicate if you plan to use a Dual Power buss. Note that a Dual Buss is when both busses are active all the time and each power buss has its own battery and alternator. Systems will be prepared for Single Power Buss unless you ask for Dual Power Buss setup. Only difference will be wires at the DPDT switch, 2nd set of switch contacts will be unpopulated with red and purple wires. Wires could be added later if changing to Dual Buss. If Single Power Buss, then the 2nd set of switch contacts aren't used but could be wired to annunciator lights or to an EFIS unit for switch position indication.

6 Cylinder Dual ECU Sensor information

Both ECU's have their own Air Temp and CHT sensors. There is only one Throttle Position Sensor but this is not a critical sensor so the signal is shared between each ECU. If you lose power on the Primary ECU then the TPS will not function, but this will only result in slight hesitation if throttle is opened quickly. The engine will run the same at steady throttle without a TPS signal.

Hall sensor 9 pin D Sub

Plugs into the middle DB-9 port on the ECU. On Dual ECU systems, the primary harness and Hall sensor cable is color coded green, plugs into the Primary(top)ECU and the backup ones are color coded red plugs into the Backup(bottom) ECU

DB-9 Pin#, function, Tefzel cable colors:

- 5, +5V, orange stripe
- 4, Trigger, solid white
- 3, Ground, blue stripe
- 8, Sync signal, green stripe.

Wrap electrical tape around the cable several times to fill the gap where the cable exits the DB hood.

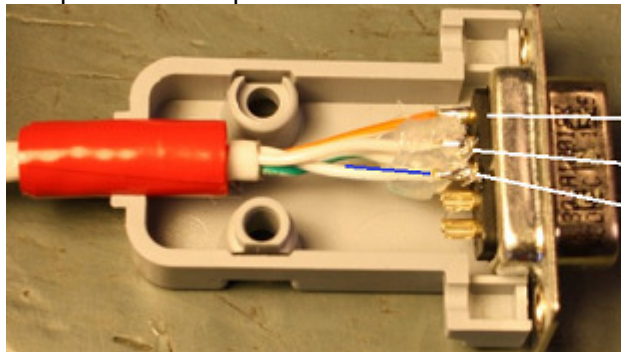

- ORANGE STRIPE
- ALL WHITE
- BLUE STRIPE
- LOWER ROW, GREEN STRIPE PIN8. NOT VISIBLE

Programmer Cable(s)

These connect the ECU(s) to the programmer. Each ECU has a cable to plug into the programmer. Pay attention to the labeling to be sure primary ECU is plugged into primary programmer port and backup to backup.



Panel Mount Programmers

For maximum flight safety, we recommend all aviation applications have a programmer connected in the cockpit.

The Design1 EFI AERO programmer unit works with single or dual ecu's. Designed to mount in the radio stack (6.25 inches wide). Cutout opening is 5.636" wide by 1.366" high, with .195" corner radii. Cutout dimension are zero gap so expand opening by desired amount to allow for powder coating. Mount holes need to fit #6 screws. Mounting hole spacing is 5.95" x 1.166". Use #6-32 x 3/8" long screws to mount. Mounting hole dimensions from cutout opening are .157" to sides of cutout and .100" up from bottom of cutout and .100" down from top of cutout.

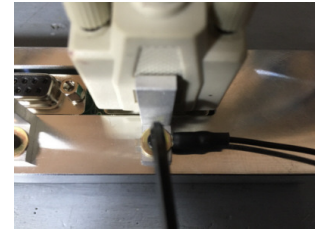
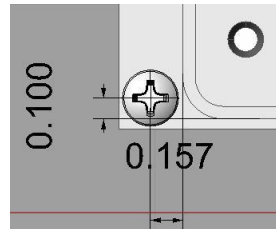

The Primary ecu cable goes to the right side connector as viewed from the rear. Backup ecu goes to the left connector. The 2ft black wires goes to chassis ground for static protection. L-brackets are to support the cable weight. Be sure they contact the cable connector and adjust as needed. The L brackets have slotted holes. Be careful swapped connectors can lead to confusion later!

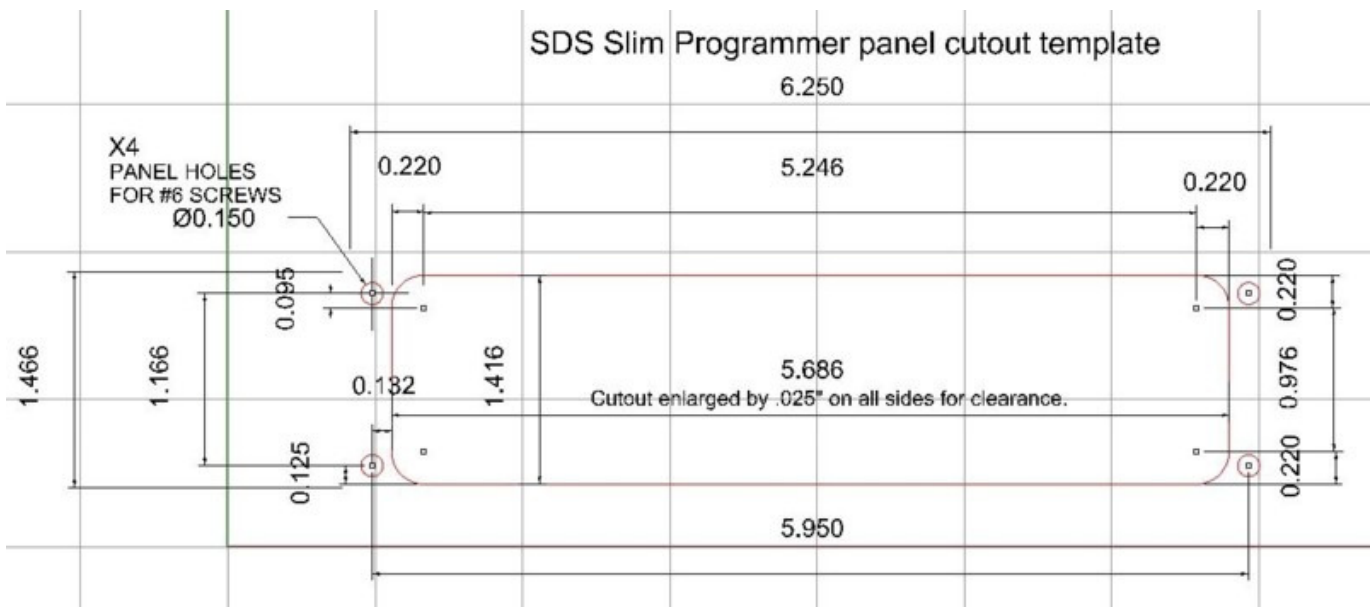

Be aware that the diagram above has a larger cutout to allow for powder coating thickness, you may wish to shrink the cutout for less clearance. Actual spigot dimensions are 5.672 X 1.366".

Programmer Mounting, 3-1/8" Style Programmer unit

Some people may choose to install the older panel mount programmer which fits in a standard 3 1/8 instrument cutout. Both programmers have dimmable internal backlighting of the LCD. Programmer serial cables are available in 3, 6, 10 and 15 foot lengths. Unlike the Design1 programmer, this programmer uses external switches for LOP activation and accessing A or B ECU. 3-1/8" Programmer unit cable connections:

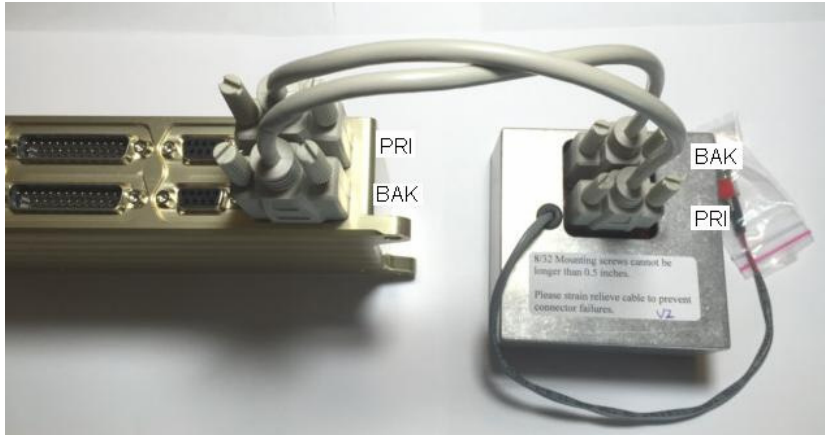

Dual board ECU with dual board 3 1/8 round programmer and toggle switch. See end programming section for details.

Mixture knob Mounting

The mixture knob allows quick leaning and richening of the mixture without any reprogramming. It can be used to lean the engine in cruise if you run LOP. Think of it as a conventional mixture control.

We recommend that it's always permanently installed as it gives the user important override control in the event of some sensor and fuel system malfunctions. Try to mount it in such a way and location where it cannot be inadvertently be bumped. The tang should engage a 1/8 inch hole vertically above the main 3/8 inch diameter mounting hole in the panel. This indexes it properly for full range control (+/- 50%).

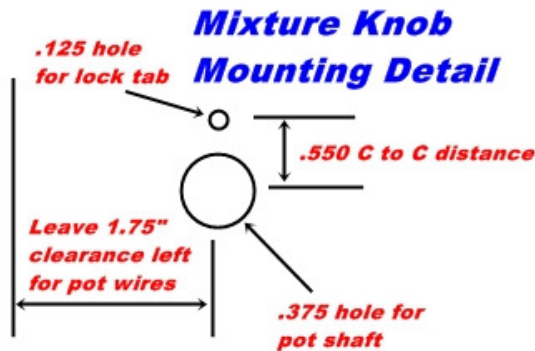

SDS Card Logger

The EM-6 introduces an external data logging module which connects to the primary ECU via the supplied audio cable. This uses a 32Gb card (supplied), and is the maximum sized card that can be used. This allows you to continuously log all ECU data and view it using SDSdash software on a Windows device. SDSdash also allows you to view and print your ECU values.



Mounting can be either in the panel using 6-32 screws through the face or on the lower flange of the panel using #8 screws through the provided flange. The upper cover plate may be reversed for additional space near the panel surface if required.

Electrical connections are Red to +12V and Black to Ground. Breaker/Fuse with 2 amps. Included 1/8" male-male audio cable plugs into the rear of the Logger and the other end plugs into the SDS gold ECU, if dual ECU, then plug into the Primary (top) ecu.

SDS LOGGER FRONT FACE DIMENSIONS

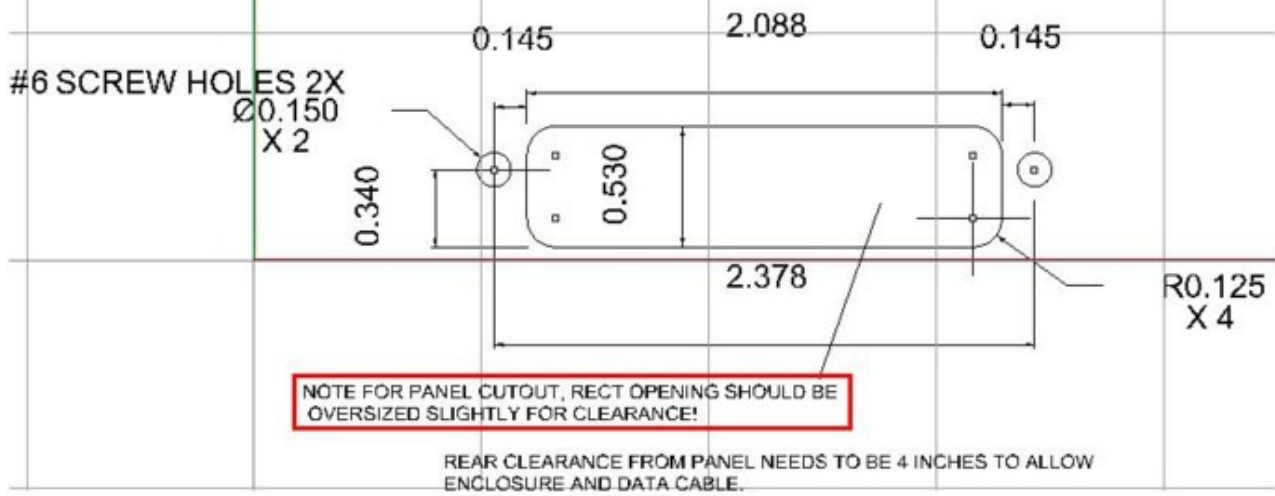

SDS LOGGER TOP VIEW AND FLANGE DIMENSIONS

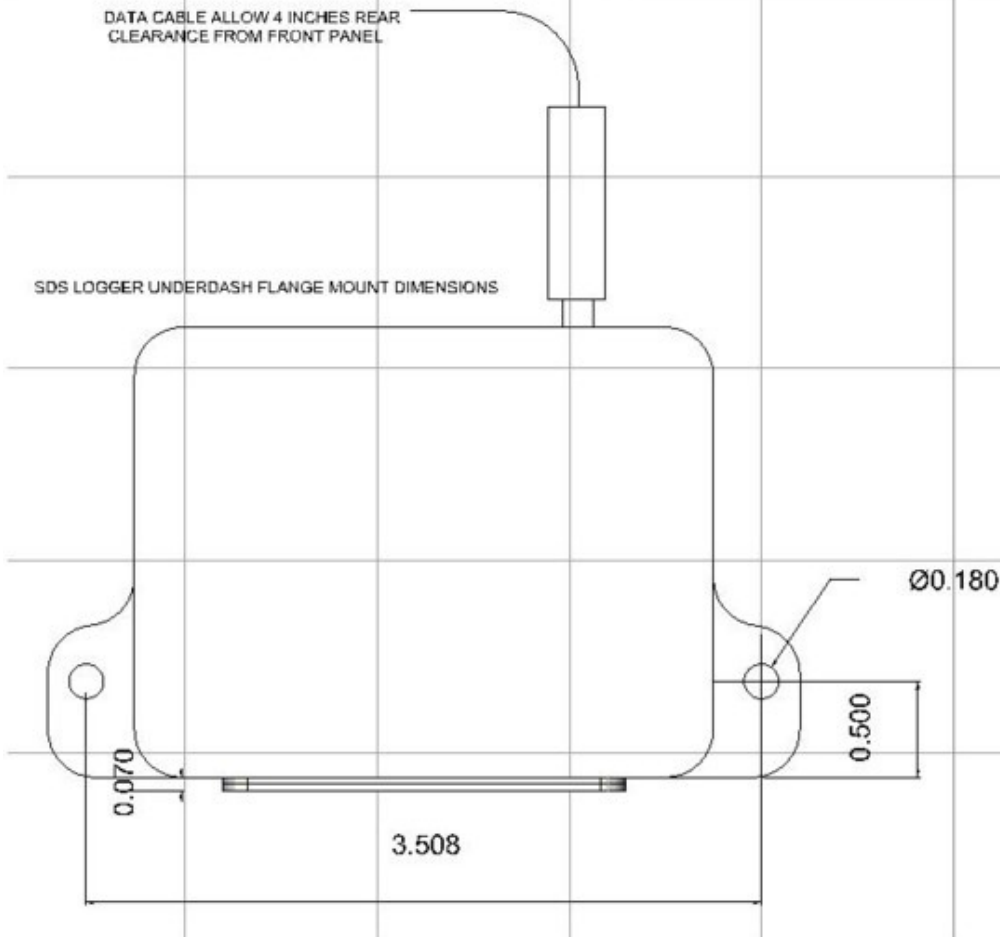

See more details in the System Programming section below in this manual.

Coilpack numbering

For systems controlling ignition, coilpacks will almost always be supplied with the kit and numbered for your particular engine. Most 4 cylinder engines use default numbering scheme cast into the coilpack except for VW air cooled or inline 4 cylinder engines, which must be renumbered. Be careful if you change to a different engine or you buy a used system and have a different engine than the system was sold for, because coils may need to be renumbered.

Lycoming 6cyl be aware that Top mount and Mag mount coilpacks are numbered differently. Top Mount Coilpacks may be numbered and wired like the Mag mount.

These are fired in a waste spark configuration, which means two plugs are fired at the same time. One plug is fired on compression, the other on exhaust when no mixture is present. For convenience of connecting plug wires you can swap sides with numbering too if this helps with routing plug wires, for example on the inline 4cyl configuration you could run cyl #1 plug wire off the right side (#4 in diagram below), and run the #4 cyl plug wire off the left side (#1 in diagram) because these are the same coil so both fire simultaneously, which is called the waste spark system. So you could swap the numbers side to side in all the coils in the diagram below.

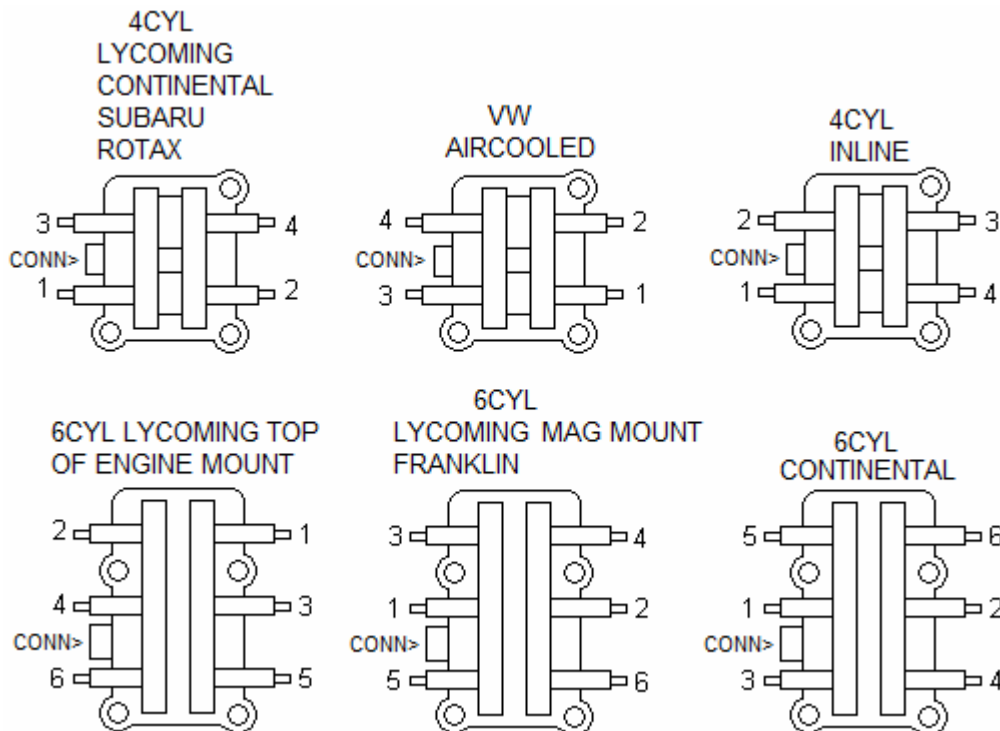

Spark Plug Wires, Boots and Terminals

We can supply MSD 8.5mm Superconductor wires, MSD plug/coil boots and MSD terminals to properly fit your coil packs. If you don't use these components, be sure to always use quality EMI/ Magnetic Suppression wires. **Never use solid core, non-suppression wires with SDS. You must always use resistor type plugs as well.** Keep the wires away from exhaust pipes or anything which could chaff through the insulation. Be sure to properly crimp the terminals as shown here:

<https://www.youtube.com/watch?v=8kQDSlpKrCw> and see the file at the end of this manual. Make your longest wire first and add 1 inch in case the insulation pulls away some of the conductor with it when stripped. Lubricate the terminal and ID of boots with glycerin based hand sanitizer before trying to slide boot over terminal. We recommend you purchase MSD crimping tool PN 35051 or if you have a similar crimper, you can buy just the jaw set PN 2048. This does an excellent job.

If you are running twin coil packs, you should run a plug wire from each coil pack to each plug on a cylinder. This provides maximum redundancy in the event that one coil pack fails.

MSD INSTALLATION INSTRUCTIONS

Dual Crimp Terminal Installation

ONLINE PRODUCT REGISTRATION: Register your MSD product online and you'll be entered in our monthly 8.5mm Super Conductor Spark Plug Wire give-away! Registering your product will help if there is ever a warranty issue with your product and helps the MSD R&D team create new products that you ask for! Go to www.msperformance.com/registration.

The terminals supplied feature a new Dual Crimp Terminal. The benefits of the new wire terminal is that the conductor has its own crimp to the terminal so it does not need to be bent over and pressed between the terminal and the sleeve of the plug wire. Following is a new crimp procedure for the Dual Crimp Terminal.

1. Strip approximately 1/4" of sleeving from the wire. When using the Mini-Stripper-Crimper, **do not** push the wire all the way into the tool to strip it. **Note:** Use extreme care not to damage the conductor.
2. Follow the standard instructions to crimp the terminal to the sleeve of the wire. **Do not** use the Mini-Crimper to crimp the conductor.
3. Position the conductor between the "conductor tabs" of the terminal. Using needle nose pliers, push the tabs towards each other so they firmly grip the conductor. Make sure the conductor does not squeeze out as you apply pressure to the tabs.

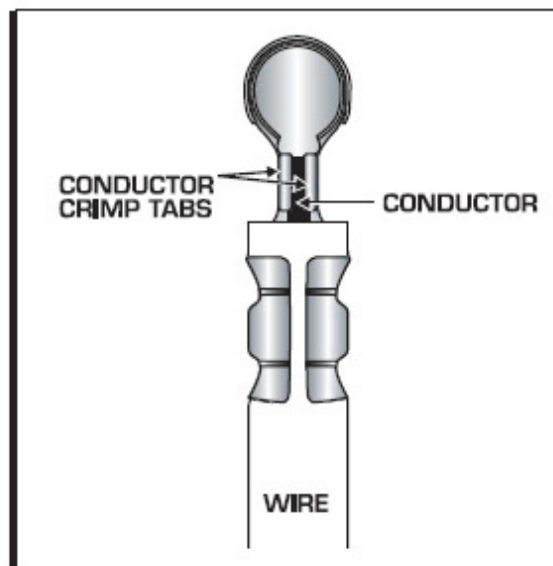
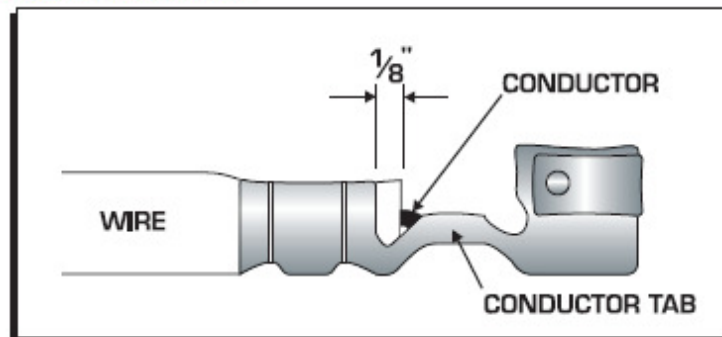

Be sure you push the plug and coil boots all the way down to engage the terminals fully with a "click". There should be about a 1/8 inch gap as shown in the photo below

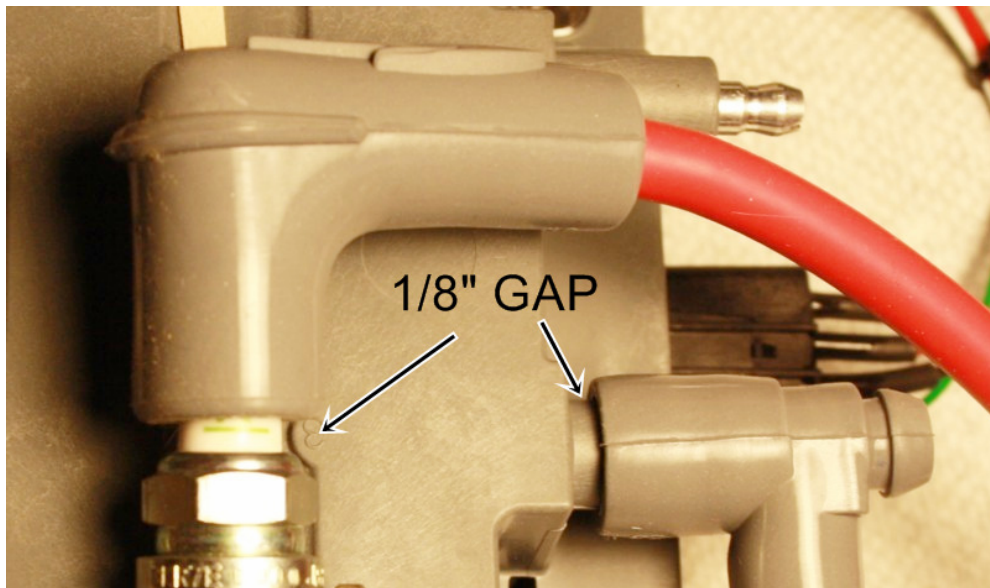

*******End of Electrical Section*******

System Operation and Programming Section

EM-6 Reset

Any time that the power is shut off or interrupted to the ECU, or if interference prevents the software from executing properly, the EM-6 will automatically perform a reset. This takes about 0.5 seconds and the engine will falter during that period. When this happens, the SDS EFI startup screen will appear in the LCD window. Reset can also be caused by the switching of high current devices such as electric pumps, motors or solenoids. These devices cause high voltage spikes that are difficult to filter. Filtering can sometimes be successful if a rectifier diode is placed across the offending solenoid, motor etc. The striped end (cathode) of the diode should connect to the (+) terminal and the other side of the diode to the (-) terminal. **Never attempt to fly the aircraft if your ECU is resetting on the ground! This indicates there is a serious issue. Find it and fix it before flying!**

Shutting off Power and Memory

Programmed values are stored in the ECU microprocessor in EEPROM memory, which holds the values in memory when power is turned off, needing no battery power. As soon as you change a value with the programmer, it is permanently changed and stored in EEPROM memory. Disconnecting the aircraft battery will have no effect on the SDS system.

Disconnecting the LCD Programmer

Set the VALUES LOCK to the ON position before disconnecting the programmer. No data will be lost. Data is stored in the ECU.

Injector Drivers

Injector drive transistors may be triggered in ones, pairs, threes or fours depending on application. Some four and six cylinder aircraft ECUs optionally fire the injectors in ones to allow for individual cylinder fuel trimming.

Air Temperature (AT)

The air temperature correction map is pre-programmed when delivered, and is not normally user accessible. It provides an absolute density correction relating to cues from the air temperature sensor. AT is displayed in GAUGE mode.

Mixture Knob (KNOB)

The mixture knob controls the overall mixture across all ranges. In effect, it adds or subtracts a percentage to the injector pulse width. From the straight up or 12 o'clock position, the mixture can be leaned roughly 50% by turning the knob fully counter clockwise or 50% richer by turning it fully clockwise.

The knob is very useful in determining a rich or lean condition and can be used in cruise flight for leaning the mixture in LOP operations and we recommend it be mounted in all aviation installations. **The knob allows quick changes of mixture without re-programming in the event of some sensor or fuel system malfunctions so should always be installed in aircraft.** Be sure to complete all programming with the knob in the 12 o'clock position so the ECU defaults to best power mixture with the knob at 0% correction. Precise return of the knob to an exact position can be noted in gauge 2 mode under KNOB. A +%, 0, or -% indicates rich, neutral or lean position.

LCD Programmer



The programmer allows you to access all points within each parameter and change values to program the system. When powered up, SDS EFI should appear in the LCD window along with the system type, software version and burn#. From here, parameters may be called up by pressing the right or left parameter select buttons (< or >). LOP activates Lean of Peak function, blue LED illuminates when active.

Fault LED



If this red LED is flashing, then check Gauge1 screen RPM, MAP and Temperature readings to see if any display ERR. If none do, then the fault is likely low main voltage which may be common if electronics are powered up but the engine is not running. In Gauge screens you can press the plus key to attempt to clear and faults (ERR) if the fault is still lit, check voltage in gauge3 mode, if below 12.5 V then voltage is the cause of the fault LED flashing

A B Prog key



On Dual board EM-6 systems, this key is used to access and program each ecu separately. LED's indicate which ecu is being accessed. For systems using the older 3-1/8" round style dual programmer, a toggle switch is used to select which ecu is accessed. A message will appear when the switch it changed stating Primary ECU or Backup ECU for about 1.5 seconds.

Dual ECU's: You will need to remember if you change a value in the A-Primary ECU you will need to also change the same value in the B-Backup ECU with a few exceptions: Magnet Position, this value will be different in the Backup ecu vs. the Primary ecu.. Programming can take a lot of time because of having to duplicate values and must be done carefully.

Do not duplicate certain Setup Mode settings such as Config values. These are different in the Backup vs Primary ECU best to never change Config numbers unless you consult with SDS first. For most people entering Setup Mode may only be needed if using the Fuel flow output option. Best advice here is stay out of Setup Mode, more details on Setup Mode further into the manual.

As each parameter is gone through using the <<,< and > keys, the next parameter will appear in the window. The + and – buttons are used to either increase or decrease the value of each parameter or command other functions when prompted in the screen. Gauge button returns you to either Gauge 1 or Gauge 4 screen (selectable).

The parameters will automatically loop back to the opposite end upon reaching one of the end selections. By holding down either the right or left parameter select buttons for more than 2 seconds, ranges will advance at the rate of 8 per second until the button is released at the desired location. The << button advances left at 20 frames per touch and can be held down for extremely fast scrolling.

Within each parameter, there are a number of ranges with a corresponding value number beside it. This value number is the one that will be changed to alter the injector pulse width. ie. RPM FUEL 2500, 157. RPM FUEL is the parameter, 2500 is the range and 157 is the value. The value number may be any number between 0 and 255 on most parameters, (350 on RPM Fuel) however some parameters have limits. The larger the number, the more fuel will be injected at that parameter and range.

To change a value, use one of the 2 buttons labeled +1 or-1. Each button will change the value in the window each time it is depressed by that amount. IE. With a 148 in the window, Pressing the –1 button

once will change the value to 147. By holding down these buttons for more than 2 seconds, values may be changed quickly to the desired figure. Don't play with these unless you want to change the value. **The VALUES LOCK feature must be selected OFF in order to adjust any values.**

Boot up screen:



Parameters will appear in the programmer window in the following order, moving right with the > button:

GAUGE 1
GAUGE 2
GAUGE 3
GAUGE 4
GAUGE 5
MAGNET SEEN/NOT SEEN (F only) or TACH 1/0(D only)
SETUP MODE ENTRY
TIME AND DATE
CARD LOGGER STATE
CARD LOGGER RATE
LCD BRIGHTNESS
LCD CONTRAST
GAUGE BUTTON SELECT, GAUGE1 or GAUGE4
LOP FUEL TRIM, 4 windows (Locked feature if not activated)
LOP CONTROL SELECT
LOP MAX MANIFOLD PRESSURE
LOP IGNITION ADVANCE
LOP LEAN FUEL ENABLE or DISABLE
LOP LEAN FUEL AMOUNT %
CRANK IGN RETARD (F only)
FUEL TRIM 4 windows (Spare windows if not activated)
LEAN WARNING
A/C FAST IDLE or NITROUS RETARD (F only, not normally used in aviation applications)
PIN 13 INPUT selects use of aux input on some systems typically this window will not be used for aviation applications with new additional LOP windows above unless external switch is preferred
O2 TYPE (standard or wideband)
IDLE FUEL AMOUNT (not used on aviation typically)
IDLE TP LOCATION (not used on aviation typically)
RADIATOR FAN ON
RADIATOR FAN OFF
FAST IDLE SWITCH (not used in aviation applications)
RPM SWITCH ON AT (usually used on Honda VTEC engines)
FUELCUT BELOW TP (not used in aviation applications)
FUELCUT/RPM
FUELCUT/MANPRESS
VALUES LOCK ON/OFF
CLOSED LOOP ENABLE SELECTIONS
CL LO RPM LIMIT
CL HI RPM LIMIT
CL MAP LO
CL MAP HI
LO OCTANE MIN RPM
SPARE 3
LO OCTANE SWITCH RETARD

MAGNET POSITION (E, F only)
 START CYCLES
 START 32 points
 RPM IGN (E,F only) 38 points
 IGN RET-ADV/LOAD (E,F only) 64 points
 ENGINE TEMP 32 points
 MANIFOLD PRESS 64 points
 RPM FUEL + AFR TARGET 38 points
 ACC PUMP SENSE
 ACC PUMP LO RPM
 ACC PUMP HI RPM, then, back to GAUGE1.

Gauge Modes

Calling up the gauge modes allows you to see in real-time, the sensor inputs to the ECU. This is useful for viewing engine data, programming the system and diagnosing sensor problems. **If you encounter a strange problem or misfire, always select the gauge modes first to see if everything makes logical sense.** This will also show error codes. Most problems can be quickly diagnosed here if you understand the system. Gauge modes update at approximately three times per second.

Gauge 1 Mode and Error (ERR) Codes

If you are in any parameter in the LCD Programmer you can push the GAUGE button to jump to gauge 1 mode. Push the GAUGE button again and the programmer will jump back to the parameter that you came from.

You can also reconfigure the programmer to go to either gauge 1 or gauge 4 mode when the gauge button is pressed. Use the +1 button to toggle when in the window below:



Gauge 1 or 4 mode can be accessed by pressing the gauge button once.



Gauge 1 mode showing error codes

MP displays engine vacuum in inches mercury absolute. The MP reading will change to ERR if the map sensor loses its connection on the ground or power wires. If you see ERR check the connector at the sensor and also check the wires for breakage. The sensor may have failed also. ET and AT are engine and air temp readings which will also read ERR if the circuit is broken. For MAP and temp sensors, ERR will stay displayed even if the fault was momentary. You can attempt to clear ERR by pressing the +1 button when in Gauge1 or 4 mode. If the ERR clears, then the problem was intermittent, and if the ERR stays displayed then there is a problem such as a broken wire or damaged sensor. **Never attempt to fly the aircraft with ERR codes displayed on the ground!**

Gauge 2 mode

Gauge 2 mode can be accessed by pressing (>) once when in gauge 1 mode.



Gauge 2 mode

Knob indicates the mixture knob position, +/- 50%. 0% (no correction) is with the witness mark straight up at the 12 o'clock position.

AP indicates the acceleration pump feature, which adds extra fuel as the throttle opens. AP should read zero when the throttle is steady. The AP number should increase above zero as the throttle is opened quickly. If AP reads a value higher than zero when the throttle is stable, the throttle position sensor may be faulty.

Duty Cycle (DUTY) refers to the amount of time that the injector remains open in relation to how much time is available at that rpm before the next injection cycle begins. If the engine is missing or running rough check DUTY for unstable readings. This may indicate a bad sensor or wiring issue.

The maximum continuous duty cycle should never exceed 85%.

Ignition (IGN) F Models Only (Fuel only models will not display ignition parameters)

A positive sign indicates that the ignition timing is **after** TDC. If timing is after TDC, ignition programming could be wrong. Having ignition timing after TDC will cause major loss of power.

IGN



If you need to get to gauge2 from any parameter you can do the following. Push GAUGE, then the > button to get to gauge2, then the < button back to gauge1, then push GAUGE button to return to the previous parameter.

Gauge 3 Mode

Gauge 3 mode is accessed by pressing (>) once, when in Gauge 2 mode.

The top line displays battery voltage and throttle position (TP). Second line displays the A/F ratio and barometric pressure. An optional setup allows another temperature sensor input to be displayed with the Baro readout. These alternate every 2 seconds.



Gauge 3 mode

Gauge 4 mode

Gauge 4 mode is accessed by pressing (>) once, when in Gauge 3 mode.

This gauge mode displays the most popular engine information on one screen. Manifold pressure, RPM, AFR (O2) and ignition timing

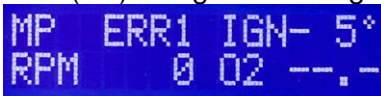

Gauge 4 mode

Gauge 5 mode is accessed from Gauge 4 mode by pressing (>) once, when in Gauge 4 mode

This screen displays O2 AFR, Target AFR, Mixture Knob % and Closed Loop fuel trim %

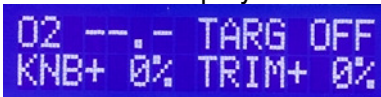

END OF GAUGE MODE SECTION

Magnet Seen/Not Seen window

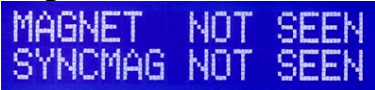

MAGNET NOT SEEN
SYNCMAG NOT SEEN

This window is used to check hall sensor alignment with magnets. To check alignment you must rotate the crankshaft very slowly by hand. Some SDS Hall sensors are adjustable, so sensor alignment with magnets is very critical to system operation.

The LCD window will change to SEEN when a magnet is over the sensor. Check all magnets for being SEEN if troubleshooting a no start condition or misfire at higher RPM's. **Each magnet should be SEEN for at least 2 to 3 degrees of crank rotation. This window is not valid if the engine is running.**

Basic SDS Fuel Tuning

Important programming and tuning tips:

CLOSED LOOP **MUST** be turned OFF when programming fuel values, and it is normally off when shipped from the factory. We highly recommend using a wideband mixture meter O2 sensor to aid in tuning.

Let the engine reach full operating temperature before fine tuning any MAP or RPM values. If you try reprogramming while the ECU is still adding extra fuel for warmup, you are wasting your time and getting off track.

You must vary only one parameter at a time and observe the AFR meter. If you change both rpm and MAP, you don't know which parameter is affecting the air/fuel ratio. Hold MAP constant and vary rpm or vice versa, never both.

It's vitally important that you understand- injector open time (the amount of fuel injected) is a result of the RPM FUEL value TIMES the MAP FUEL value. RPM values address fueling changes related to volumetric efficiency (engine breathing). MAP values address load. These are two separate parameters which come together in the ECU to determine how much fuel is injected.

Make absolutely sure that fuel pressure is staying where it should, that all injectors flow the same volume, have good patterns and that injectors, filters and pumps have sufficient flow rates to feed your engine at full power. **No amount of programming will fix inadequate fuel flow caused by a mechanical fuel system problem.**

You should first become familiar with all the different programmable parameters by reading the main SDS manual.

Improper programming of fuel and ignition parameters can cause engine damage and a complete power loss in extreme cases.

Background Technical Information

Air/ fuel Ratio

In most spark ignition, internal combustion engines, the mixture is combustible within an AFR (air/fuel ratio) range of roughly 9 to 1 to about 18 to 1. 9 being very rich, 18 being very lean. 14.7-15.2 is the stoichiometric ratio (chemically correct) for lowest emissions. Best power is obtained at around 12.5 for most naturally aspirated engines.

SDS Fuel Tuning

The fuel tuning has been written in the sequence that we recommend tuning the system. RPM FUEL first, followed by Manifold Pressure, Acc pump, Engine Temp, Start, closed loop and fuel cutoffs/limits.

The amount of fuel injected by the EM-6 is determined by the values in rpm fuel, manifold pressure, acc pump, engine temperature, start, air temperature. Once, the engine is at full operating temperature, the main values that determine the fuel mixture are RPM FUEL and Manifold Pressure. Most of the Manifold Pressure values can be left at their factory settings when the RPM FUEL values are set properly. RPM FUEL values are where programming should begin.

RPM Fuel

The rpm band is divided into 38 ranges, either 100 or 250 rpm apart. **This parameter is where the main fuel programming is done in SDS systems.** The variables which ultimately determine the RPM FUEL values are engine displacement, injector flow rate and volumetric efficiency of the engine. Volumetric efficiency varies with RPM. As a result, RPM FUEL values will vary accordingly. If a richer mixture is desired at certain RPM's, the RPM FUEL value will need to be increased. There should not be large changes in adjacent values in RPM Fuel, rather smooth transitions.

Example here, the LCD display shows one RPM Fuel window. The RPM range is 1800 and fuel amount number is 165.



RPM FUEL 1800 165
O2LOG --.-

Your system has a base map entered for the recommended injector flow rate or for the injectors included in your kit.

Often people have their RPM FUEL values incorrect and find themselves having to re-slope the entire 64 manifold pressure values, which can lead to further problems. When the RPM FUEL values are setup correctly, the majority of manifold pressure values can be left unchanged, thus greatly simplifying tuning of the engine.

If you double the RPM FUEL value, this will double the pulse width of the injector pulse. If you wanted to make the mixture 10% richer then you would simply add 10% to the RPM FUEL value. Example: RPM FUEL value was 100, and is then changed to 110. This would add 10% more fuel to the mixture.

It is important to note that the number of injections are doubled when the rpm is doubled regardless of the values entered. See figure 4.

The maximum RPM fuel value is 350.

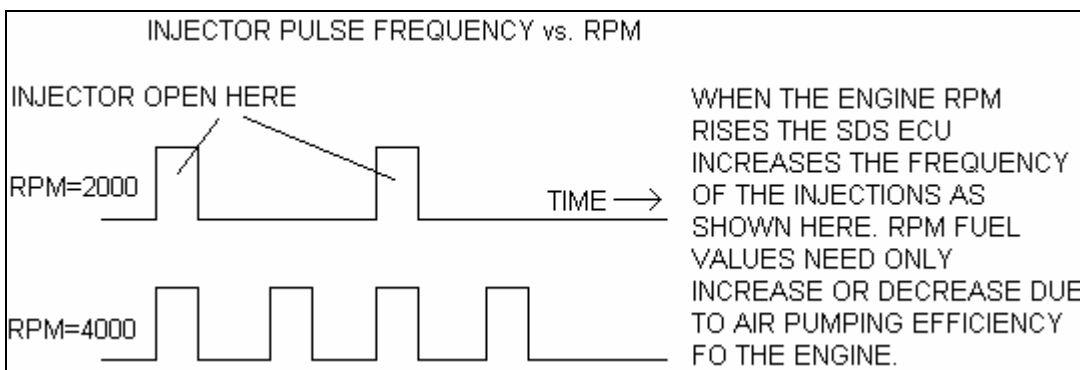

Startup Procedure

Make sure that fuel at the correct pressure is present at the injectors. Turn on ignition and computer power. Crank the engine, rotate mixture knob richer while cranking. If engine does not fire, see troubleshooting section. You may also have to increase the START values to get the engine to fire.

Once the engine is running, use the mixture knob to get a smooth idle. Let the engine warm up to normal operating temperature. Once warmed up, attempt to set the knob near the center position (12 o'clock). To do this will most likely require adjustments to the RPM FUEL values. If the knob is on the rich side of 12 o'clock, the RPM FUEL values are too low and vice versa.

On F systems, you must set the MAGNET POSITION parameter as soon as the engine is idling smoothly before performing any other adjustments. Refer to that section of the manual. For Lycoming using SDS factory hall bracket Magnet Position values are preset already.

Fine tuning RPM FUEL values

We normally want to aim for around 12 to 1 AFRs and this is best determined using a wideband AFR meter. You can read the AFRs in gauge 3 or 4 screens. AFR is displayed as O2 in Gauge 4 as shown below.



```
MP ERR1 IGN- 5°
RPM 0 02 --.-
```

Correcting the Mixture Using a Wideband AFR Meter

Example #1: At 2500 RPM say, we have an RPM FUEL value of 108. The A/F ratio is 14.7, but we would like to make the A/F ratio 13.5.

Correction= $14.7/13.5$

Correction= 1.09.

Now we multiply the RPM FUEL value by 1.09.

$108 \times 1.09=117.7$. Round off to 118.

Example #2: At 2000 RPM say, we have an RPM FUEL value of 108. The A/F ratio is 12.5, but we would like to make the A/F ratio 13.5.

Correction= $12.5/13.5$

Correction= 0.93

Now we multiply the RPM FUEL value by 0.93.

$108 \times 0.93=100.44$. Round off to 100.

With a wideband sensor, best power will usually occur with an A/F ratio of around 12.5:1, however automotive type engines may not tolerate running this lean due to piston thermal considerations and air cooled aircraft engines may not cool sufficiently. We recommend most engines be set up to run around 11 to 11.5 AFR during high power conditions- WOT, takeoff and climb. See the appropriate supplemental manual for your engine type for more detailed specific information.

Manifold Pressure, MAP or MP

There are 64 programmable ranges in the manifold pressure chart for adjusting fuel. Data in the manifold pressure chart determines the relationship intake manifold pressure and the amount of fuel injected. Aviation EM-6 systems are calibrated in inches of mercury absolute. There are 3 different MAP sensors used with the system which cover a different range of pressures. All units are pre-programmed with a standard MAP value chart depending on the MAP sensor used. These values should be close, so most initial programming is usually done on the RPM FUEL values. **MAP values generally increase in a near linear fashion as manifold pressure increases.** Your MAP values should never go up and down like a saw tooth.

Example Manifold Pressure window, manifold pressure is 28.5 in AB, and the fuel number is 128.



```
MANIFOLD PRESS
28.5 128
```

The more open the throttle is, the higher the manifold pressure, so the manifold pressure values must be larger. SDS delivers a longer injection pulse to put more fuel into the cylinder. By adjusting the manifold pressure values from their default, you can change the mixture of the engine at different MAP to achieve best power or economy.

Use Gauge 1 mode to see what manifold pressure range the engine is running in, then use the < > keys on the programmer to move to the range you want by adjusting the values if desired.

Lean Warning

For aircraft in most cases leave this Disabled. Requires a wideband O2 kit and unleaded fuel! This feature allows some protection against a lean condition at higher throttle openings. You must have a wideband meter that has an analog output connected to the SDS main harness gray wire and a TPS installed for this feature to operate. This feature may not be reliable with leaded fuels since they affect operation of O2 sensors. If enabled, the system will monitor the O2 sensor voltage, and when throttle position is 35 or higher, and if the mixture is leaner than approximately 14 to 1 for 2 seconds, then an ERR message will be displayed in Gauge 3 and Gauge 4 modes in place of A/F or O2 volts. Also this will turn on the check engine light output on the ecu. The ERR message and check light remain until you manually clear them by pressing +10 while in Gauge1 mode. The ERR message and check light also clear when SDS is powered down.

There are 3 settings for this parameter:

1. Disabled. Correct setting when no O2 sensor is connected to the SDS ecu.
2. Enabled. Turns on Check light, and displays ERR in Gauge modes. Does not add fuel.
3. Enabled + add fuel. This does the same as the Enabled setting, plus when the ERR occurs, 25% will be added to the fuel mixture above throttle position 35. This may help prevent engine damage by allowing the tuner time to acknowledge the problem and close the throttle. To clear the ERR message press +10 while in Gauge1 mode, then this will remove the extra 25% fuel. Then further tuning or troubleshooting should be done.



LEAN WARNING
ENABLED

We recommend that lean warning be disabled on engines which will routinely be running lean of peak (LOP).

Lean Warning should be set to Disabled when there is no TPS installed.

Lean Warning may not function long term when Leaded fuel is used since the lead may foul the O2 sensor. Lean warning will not function unless a TPS is used.

The Lean Warning will not function if O2 Type setting is "NONE".

Idle

It's best to adjust RPM FUEL values first to get the best idle mixture. If you have a wideband meter, a good target mixture for idle is 12 to 13. Don't adjust fuel numbers just because the engine is idling too fast. If the engine is idling too fast, adjust the airflow on the throttle plate set screw, then recheck and adjust the RPM FUEL ranges where the engine is idling. Usually keeping RPM FUEL numbers from 500 through 1200 equal is also a good idea. This will help keep the idle from surging up and down.

If idle still seems a bit unstable, then you may need to also adjust a few MANIFOLD PRESSURE values to improve smoothness. To do this, press the Gauge button to see gauge1 mode, note the MP reading on the top left. Then scroll left and into the manifold pressure values, just above and below where the engine is idling at, and make the values all equal. We have done this by default around 10" vacuum, but some adjustment might be needed. If the MP fluctuates over more than 3 ranges, you may have to install

a .025 to .035 inch orifice in the MAP sensor line to help average and stabilize the vacuum seen by the SDS computer. This orifice should be inserted close to the manifold/ throttle body connection.

Acceleration Pump (ACC Pump)

You must have a TPS installed to have this function active. If you don't have a TPS on the engine set the two Accpump Hi & Lo Rpm values to zero and Accpump sense to 1. ACC PUMP values help give smooth throttle response when the throttle is opened quickly. There are three adjustments to make for the acceleration pump. Adjustment should be done when the engine is at normal operating temperature.

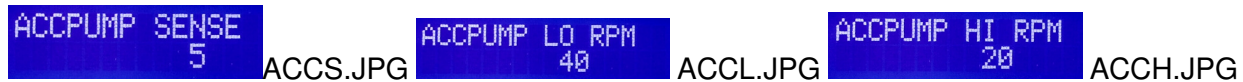

ACCPUMP SENSE 5 ACCS.JPG ACCPUMP LO RPM 40 ACCL.JPG ACCPUMP HI RPM 20 ACCH.JPG

The ACCPUMP LO RPM value controls action from 0 to 1800 rpm. With the engine idling, quickly open the throttle. If the engine hesitates, change the value. If the hesitation is worse, you have changed the value the wrong way. Find the value that gives the best, quick throttle response.

Next is to adjust the ACC PUMP SENSE. This is very important just out of the idle range. Set this control by opening the throttle slowly from the idle position. Adjust for the smoothest acceleration. 1 is least sensitive, 8 is most sensitive. Usually 5 or 6 is best for most applications.

The ACCPUMP HI RPM setting controls action above 1800 rpm Snap the throttle open quickly above 1800 rpm. If the engine hesitates, change the value. If the hesitation is worse, you have changed the value the wrong way. Repeat this procedure until engine response is acceptable.

Acc pump values are generally between 5 and 50 on most applications. The ACCPUMP LO RPM is usually a higher value than ACCPUMP HI RPM.

Engine Temperature (ENGINE TEMP, ET)



ENGINE TEMP
25°F 90

There are 32 ranges under this parameter which determine the amount of extra fuel injected to compensate for a cold engine during warmup. Liquid cooled engines use a water temp sensor and air cooled engines use a cylinder head temp sensor to supply a signal to the EM-6. The function of this parameter is similar to a choke on a carburetor.

You should aim for a 0 value when the engine is at normal operating temperature. Most engines will not require extra fuel after 100-140 degrees F. The values should decrease in a fairly linear fashion from cold to operating temperature then have 0's entered above this threshold. Temperatures can be displayed in F or C.

As a reference, a value of 127 would add 50% to the pulse width and a 255 entered will double the pulse width.

By flicking back between Gauge 1 mode and ENGINE TEMPERATURE you can make adjustments while the engine is warming up. Each time the ECU updates to a new ET in gauge mode, you can go to that ENGINE TEMPERATURE range in the programmer. Turn the knob richer and leaner and note where the engine starts to run rough on each side of 12 o'clock. If it runs rough say at 10 and 2 o'clock, you probably have the engine temp values about right. If not, adjust the ENGINE TEMP value at the engine temp displayed currently in Gauge1 mode.

Start (START)

A blue rectangular digital display with white text. The top line reads "START" and the bottom line reads "14°F 140".

Start enrichment is provided for under the START and START CYCLES parameters. The ECU reads the signal from the engine temperature sensor, looks up the START value at that temperature range, and injects extra fuel for a certain number of engine cycles after the ECU detects crank rotation. This function is activated every time that the engine is started, no matter what the engine temperature is. However, if there is a zero at the current temperature range, no extra fuel will be added. START values are critical for proper starting, especially in cold climates.

At colder temperatures, the values are high, tapering off as the engine warms up. At temperatures over 100 to 140°F, most engines do not require much extra fuel so the values should be low or 0 here. Experimentation is required for a satisfactory setup here.

It is best to not open the throttle during cranking, especially in cold temperatures. Opening the throttle will cause a leaner mixture during cranking. The engine needs a rich mixture to start. Tuning all the START values will take many days in very cold climates. You can usually only tune one value per day, and you will have to wait for colder weather to adjust the colder ranges.

Systems will do 1 injection of fuel at key-on, when the Start value is greater than 0 at any temperature. This will improve cold starting. **You must have fuel pressure prior to powering up the ECU(s) in order for this to add fuel.**

Aviation systems have special software to allow manual priming without the engine turning over. You may stroke the throttle a few times in cold conditions to open the injectors momentarily. This acts just like a primer and may aid starting in very cold climates. **Close the throttle when cranking, even if you prime.**

Start Cycles

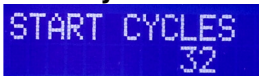
A blue rectangular digital display with white text. The top line reads "START CYCLES" and the bottom line reads "32".

The value entered under START CYCLES determines how many engine cycles START enrichment lasts for. This is the number of crank revolutions times 2 on a 4 stroke engine. Some engines require start enrichment lasting a long time, others only require a short start enrichment period. The larger the value under START CYCLES, the longer the enrichment period. This is adjustable between 0 and 255, but a value of 40 is probably as high as you would ever need, and do not set this below 10 because too low a value will make the START function expire too quickly. 15-20 in 4 cylinder engines and 20-30 on 6 cylinder engines is a good beginning point.

Both START and START CYCLES must be set carefully. If the engine fires immediately at any temperature, the START values are good. If the engine takes a lot of cranking to get running, the START values may be too low. If the engines starts quickly but then stalls after a few seconds, there are two possibilities; either the START CYCLES value is too low or when the start cycles have expired, the ENGINE TEMPERATURE values are too low. Once the start injection cycles have occurred (usually 3-10 seconds), the ECU relies on ENGINE TEMPERATURE values for warmup enrichment. **These two parameters should not be confused.** The START function is automatically reset after the engine stops turning.

Closed Loop

A blue rectangular digital display with white text. The top line reads "CLOSED LOOP" and the bottom line reads "OFF".

Generally in aviation applications if using leaded fuel, do not use the closed loop function due to reduced O2 sensor life with these fuels, O2 life can be shortened to a few hours sometimes with leaded fuel. For engines using unleaded avgas or Mogas, closed loop may be used.

When Closed Loop is set to Off, then the ECU makes the fuel injection pulse based solely on RPM Fuel and Manifold Pressure fuel values and other fuel values in the system. This is often referred to as open loop control.

When Closed Loop is turned On, then what happens is the fuel values are still used to get a base fuel injection amount just like open loop, but then a correction amount is added or subtracted based on the Wideband O2 signal feedback. If the AFR is leaner than target the ECU will begin adding to a correction amount which gets added onto the base injection amount. Conversely, if the AFR is richer than Target AFR then the ecu will begin subtracting the correction amount with ability to go negative thus making the correction subtract some fuel from the base fuel amount. Note that this action does not reprogram any values in the system, so none of your fuel values get changed, so in other words this is not a self tuning type of system but a temporary, at the moment, type of correction. This method had been used in automotive fuel injection for decades to target 14.7:1 AFR to keep exhaust emissions low. Difference here with SDS is you can adjust the Target AFR to whatever is required, be it power, economy, or cooling.

In the event that the wideband feedback does not function correctly, there are fixed limits for correction of +/-25% as well as error detection if too much trim occurs but the ecu is not seeing enough change in AFR. If ERR2 is seen in Gauge5 screen then this indicates software did not see enough change in AFR during correction. There can be some reasons for this, not that the O2 wideband has a failure but this could come from a large change in AFR target from one RPM Range to the next, or from changing throttle very slowly but not enough to restart the O2 checking. Generally the O2 error checking only occurs in steady state running, steady rpm steady throttle conditions. ERR2 can be cleared by pressing + key in Gauge5 or other gauge screens 1-4. If ERR2 is present Closed loop does not operate. O2 sensors do have a finite lifespan and in aircraft this can be a shorter life than in automotive applications due mainly to high power operation most of the time, whereas automotive is mostly part throttle. One symptom of O2 failure is the AFR reading is frozen and does not change at all if you suspect this turn the mixture knob richer or leaner the AFR reading should change immediately, if not there is a problem with the wideband, most likely the sensor or broken wiring connection.

By watching Gauge5 screen you can observe the amount of correction required to achieve the Target AFR, and this is very good data to observe and utilize to make changes to RPM Fuel values. If you are seeing a correction amount of 15% or more, then it is recommended to observe what RPM range the engine is in, and make an adjustment to that RPM Fuel value, then less correction will be required and the AFR will be much closer to Target the moment the engine enters that particular RPM range.

Closed Loop RPM and MP limits

We define automatic closed loop operation with 4 main boundaries, LO and HI RPM and LO and HI MAP as shown below:

CL LO RPM LIMIT 1200	CL MAP LO LIMIT 16.3
CL HI RPM LIMIT 1900	CL MAP HI LIMIT 24.2

When RPM or MAP is outside of any one of these boundaries, the ECU will jump out of closed loop, back into open loop, running off your programmed values.

To enable closed loop, select this window below, using the + button to scroll through the closed loop enable/ disable options.

```
CLOSED LOOP
ON, RPM TARGETS
```

This allows you to program a target air/ fuel ratio (AFR) at each RPM break point

Closed Loop Enable/ Disable Switch (Optional)

This external switch allows you to quickly turn the closed loop function on or off without using the keypad. Grounding the switch enables. See electrical section for hookup. If you have an additional external closed loop enable/disable switch and prefer to manually control when closed loop is active, select the window below:

```
CLOSED LOOP ON
RPM TARG &SWITCH
```

Having the switch is recommended so Closed Loop can be turned off quickly.

When closed loop is selected off, no AFR targets will display in the RPM Fuel value slots. With closed loop selected on, you'll see target AFRs appear in the RPM Fuel windows. With the > flashing cursor pointing at the AFR target number, you may use the + or – buttons to increase or decrease that AFR number as below:

```
RPM FUEL TARGET
2800 201 11.5
```

The + button changes the AFR target in increments of 0.2.

Press the > button twice to move to the next RPM programming range.

Best power is obtained around 12.5 AFR, best cooling around 10-11 AFR, best economy around 16 AFR.

Octane Select Switch (Optional) On systems controlling ignition

This external switch allows you to offset ignition timing a programmed amount of degrees when using lower octane fuel such as Mogas. Grounding the switch enables ignition retard.

```
LO OCTANE MIN   LO OCTANE SWITCH
RPM 1500        RETARD 5°
```

The first screen allows to to set the minimum RPM activation point for this feature. The second screen allows you to set the degrees of ignition retard when activated.

Fuel Cutoff, Rev and MAP Limiting

RPM and MAP limiting in SDS are very harsh so it is not recommended that you constantly hit the rev and MAP limits with SDS. These limits are intended for protection only, primarily for propeller governor or blade loss conditions. Set them slightly higher than your maximum limits so you don't run into them in normal operation.

Fuel Cut /RPM

```
FUELCUT/RPM
2900
```

This will limit the RPM's of the engine by cutting off fuel if the engine rev to the set RPM. With a setting of 2900 the engine will rev to 2850 RPM then at 2851 RPM fuel will be cutoff., depending on rpm steps in your programmer. Adjustments are in 100 or 250 RPM increments. RPM. Lycoming Conti 2900 usually. Rotax, much higher around 6000.

Fuel Cut/ MAP

FUELCUT/MANPRESS
NO LIMIT

If engine is non-turbo then leave set to NO Limit.

Generally only used on forced induction engines. This will limit the amount of manifold pressure to protect the engine from over-boosting resulting from a malfunctioning wastegate etc by cutting off fuel injections when manifold pressure exceeds this setting. For example, if you are running around 40 inches MAP you should set this parameter to around 42 or 43 inches, so the engine will not hit the limit under normal conditions.

Factory setting is NO Limit which disables this feature, so it will not affect the system. **If this parameter is adjusted to a low MAP range, it can cut off all fuel causing a no start condition.**

Fuel Cut/ Below TP

FUELCUT BELOW TP
NO CUT

This parameter is used to cut off fuel when gliding with the throttle closed. It is in operation only when the engine is above 2000 rpm and a TP value is entered in the window. When it is set to NO CUT the function is disabled. This parameter is usually not used in aviation applications.

RPM Switch

RPM SWITCH ON AT
1200

This feature is usually used on Honda VTEC engines to control the VTEC solenoid.

Values Lock

VALUES LOCK
OFF

This feature allows you to lock out the programmer function to prevent accidental changes to your values. To lock your values, select VALUES LOCK window in the LCD programmer. The + and - buttons are used to select it to the ON or OFF position. When you are done programming for a while or plan to disconnect the programmer always engage VALUES LOCK ON. **You cannot program the system with VALUES LOCK ON selected.**

Optional Individual Cylinder Fuel Trim

This option, when activated through a discrete pin code for each burn#, allows the user to add or subtract to the injector pulse width on each cylinder usually based on EGT readings. **Leave the FUEL TRIM value at zero until all other programming is complete.** You should only use this feature if you have an engine monitor with individual EGT probes for each cylinder. It's generally designed for engines which have unequal mixture distribution. When set correctly, all cylinders should peak at the same time.

FUEL TRIM
CYL #1 + 0%

You can trim each cylinder +/- 20% using the + or - buttons. Scroll right to access the trim windows for cylinders 1, 2, 3 and 4. (4 cylinder systems).

For 6 cylinder systems, the Primary ECU trims cylinders 1,2, 3 and the Backup 4, 5 and 6. If you use the Cylinder Fuel Trim option, when programming the trim values, be sure to have the ECU selector switch in the Normal position(not PRI or BAK). To trim cylinders, you must toggle between ECUs with the PROG key (or switch w/3-1/8" programmer). Trim cylinders 1, 2 and 3 with the primary ECU and cylinders 4,5 and 6 with the backup ECU.

Time & Date

```
TIME & DATE  
19:14 APR18 2023
```

```
TIME & DATE  
11:51 APR19 2023
```

In order to properly synch the data logging files, use this screen to set the time and date. Use the +key to enter Time Date Set mode, the cursor will appear, then use +, - and arrow keys to adjust time and date numbers and month. Press the << key to save time and date data and exit Time Date Set mode. Time and Date data is used to provide a time/date stamp for the SDS Logger.

Card Logger State

The SDS programmer talks to the SDS Card Logger and in the programmer there are two windows related to the SDS Logger unit. Card Logger State and Card Logger Rate.

```
CARDLOGGER STATE
```

Displays the status of the logger, and most commonly the amount of space in percentage remaining on the memory card. Memory percentage will take many hours to change even by 1%. Also indicated will be if the card is not installed fully or has its lock switch engaged, or is full. The SDS Logger yellow LED will also flash 3 times for no card, 4 times for locked card. Cards have a mechanical switch on the side which needs to be pushed toward the connection contacts. Beware some card switches are loose and can move into the lock position when inserting them, common with micro adapter style cards. Using a full size card non-adapter type is best. 32GB is the maximum card size compatible with the SDS Logger.

```
CARDLOGGER STATE  
+1 TO ERASE CARD
```

This message indicates the Data Logging files are not present on the memory card. Empty datalogging files are placed onto a new card. Once logging begins, then the files get populated as data gets received. Also you will have the yellow Wait LED on the Card Logger flashing 1 pulse repeatedly. Press the + key on the programmer to begin formatting the card. Warning, any files on the card will be erased immediately!

```
CARDLOGGER STATE  
CARD PREP: 17%
```

You should see the formatting process progress. This should take around 100-120 seconds.

```
CARDLOGGER STATE  
NO DATA RCVD
```

No Data Rcvd message indicates the Card Logger is not connected to the SDS ecu or the SDS logger is not powered on.

Card Logger Rate

```
CARD LOGGER RATE  
STOP LOGGING
```

```
CARD LOGGER RATE  
0.98 S INTERVAL
```

When the logger is active, you should have the green Log LED illuminated and the programmer screen should say Logging. If you have a solid Yellow LED and no green then the logging rate is set to Stop Logging. Press + key to change rate and begin logging data and the green LED should light up and the yellow LED turn off.

You can change the data logging rate in the window below using the + and - buttons. Rate choices are .065, .262, .49, .98, 1.96 seconds or Stop Logging. For normal use, .98 is usually sufficient. .065 setting may be useful for troubleshooting.

Lean of Peak (LOP) Operation

Pressing the LOP key will activate the function in the EM-6 ecu and will advance ignition timing and lean fuel depending on the settings. Note that LOP will be enabled but for the LOP ignition advance and Fuel Leaning to occur a two conditions must be met:

1. Manifold Pressure must be equal or less than LOP MAX MANIFOLD PRESSURE setting.
2. Engine RPM's must be 1500* or higher, (not adjustable).

There is no need for LOP at low engine RPM's like idle or taxi conditions. It is best to only activate LOP after takeoff when in cruise conditions. Activating LOP on the ground may make the engine lean out to where it loses power during taxi or runup and you may think there is an engine problem.

* For high revving engines (auto engine conversions & geared), SDS is set for 250 rpm increments, the minimum rpm is 2200.



LOP MAX MANIFOLD
PRESSURE 25.1

LOP CONTROL



LOP CONTROL
KEYPAD

Also note that if using the PIN13 setting here and your own toggle switch to activate LOP then the LOP key on the Design1 programmer will not function, but the blue LED will light up with your LOP switch turned On when the PIN13 input sees 6 volts or higher.

LOP IGNITION ADVANCE



LOP IGNITION
ADVANCE 1°

This window sets the amount of ignition advance when LOP is activated. Usually no more than about 5 or 6 degrees should be entered here. Just enough to smooth out LOP running of the engine. Fuel only SDS systems wont use this window since these systems don't control ignition timing.

LOP LEAN FUEL DISABLED or Use Percentage or Use Target AFR

Allows an easy way to turn off leaning of fuel mixture rather than having to change the percentage (or LOP AFR target) setting. Use + button to select.



LOP LEAN FUEL
DISABLED



LOP LEAN FUEL
USE PERCENTAGE



LOP LEAN FUEL
USE TARGET AFR

LOP Lean Fuel Amount



LOP LEAN FUEL
AMOUNT - 21%



LOP LEAN FUEL
TARGET AFR 16.0

Traditional method was to Lean fuel by a set percentage amount which does work very well. With the EM-6 if you have a wideband O2 unit connected to SDS ecu, then you can try the LOP Lean Fuel Target setting and the SDS will chop the fuel pulse initially, then trim or add fuel to achieve the Target setting for LOP. This does rely on the wideband O2 signal so if the wideband O2 has a problem this is going to cause LOP AFR to be wrong. Trim percent in LOP AFR is limited to +/- 15%. Do not select Use AFR target without having the wideband connected to SDS! Do Not use the Target AFR setting with Leaded fuel.

Reminder: If you have a 6cyl dual ecu be sure to duplicate these LOP settings in the Backup ECU since it is running injectors 4,5,&6 on the engine!

SDS systems that do Fuel only (no ignition control) can still do LOP but cannot change the ignition timing for you.

Lycoming LOP test case:

If we run best power mixture at 12 to 1 AFR for climb and wish to run LOP in cruise, we'd set MAP and rpm with the throttle and prop control. From previous flights, we've determined from the engine monitor EGT/ AFR meter and mixture knob that we like to run at about 16.5 AFR LOP. This required going 37% lean with the mixture knob. We can now program -37% into the LOP LEAN FUEL % window. Now we can quickly go LOP just by throwing the toggle switch without touching the mixture knob. The LOP feature should only be used once you're familiar with your engine and typically cruise at or near the same MAP/ RPM power settings.

Optional LOP Cylinder Fuel Trim, New for the EM-6

There is a 2nd set of cylinder fuel trim values for Lean of Peak (LOP). These trim values apply only when LOP is activated. And when LOP is activated the regular Cyl fuel trims are ignored. Maximum trim is +/- 20%.



These are intended to help balance Cylinder temps when in LOP mode of operation. If Cyl temps are close enough together then these values can stay at zero. Note, for these trims to actually function, you must have you must have LOP Lean Fuel set to Use Percentage, not Disabled.



<<< like this, not this>>>



Pin13 Input window (No Photo) , Leave set to A/C. If another window named LOP control is set to Pin13 then this will display "LOP control" on the 2nd line of the LCD as an over-ride message. To Left of this window is the A/C Fast Idle window leave set to No. These windows are used for automotive systems and are now obsolete for aircraft. These performed some ignition functions in older versions of software.

O2 Type



Sections, are WMS, PLX-AEM(Old), AEM(new), Ballenger Extreme. If you have the older Spartan wideband select PLX AEM(old). If you have the Ballenger AFR500V2 then be sure to set its jumper inside for the Extreme output voltage range, please see the Ballenger manual.

Below, Parameters without LCD Photo, most are not used on aircraft.

- Idle Fuel Amount and Idle TP Location** leave set to Not In Use
- Radiator Fan On and Fan OFF** leave alone these are not used.
- Fast Idle Switch** leave alone not used.
- RPM Switch On At** Only used on Honda Vtec engines if switching a Vtec solenoid via a relay. Usually set for 4000 rpms.

FuelCut /ManPress Can be useful on turbocharged aircraft to cutoff fuel if an overboost situation occurs.
Ignition related programming section

Crank Retard



Crank Retard helps to compensate for Magnet to Hall sensor delay time and the engine slowing down while coming up on the compression stroke, so having a value of between 10 and 30 here can help prevent engine kickback during cranking. If the engine kicks backward during cranking the increase this value. Default is 20. Also you want to have a low timing amount in RPM Ignition 500 of 10 or less.

Magnet Position

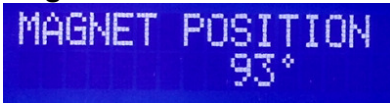

MAGNET POSITION
93°

Initial Setup - VERY IMPORTANT

Lycoming engines using the SDS CNC Hall sensor mount can skip this step. FYI, Lycoming default values here for Dual ECU Primary is 97 and Backup 88. Lycoming with single Hall sensor default is 92.

Magnet Position, all Other engines non-Lycoming please follow this procedure.

This step requires a timing light. The best timing light to use, is one that does not have a delay knob. Delay lights may not work properly with waste spark ignitions. If you only have a delay type light set the delay to 0. The flywheel/ timing disc and block must have timing marks on them. The timing light inductive pickup clamp can also be connected onto the ground wire of the coil pack unit if clipping to the spark plug wires does not work well.

This involves calling up the MAGNET POSITION parameter using the programmer. **This step should be performed as soon as the engine is fired up and idling. Ignition timing is meaningless without first setting the MAGNET POSITION parameter properly.**

A value of between 70 and 90 entered should allow the engine to be started. 80 would be a good starting point and is where the system is factory set.

STEP 1. Using the Programmer set the following parameters:

- RPM IGNITION 500 to a value of 10.
- RPM IGNITION 750 to a value of 10.
- RPM IGNITION 1000 to a value of 10.
- RPM IGNITION 1100 to a value of 10.
- RPM IGNITION 1200 to a value of 10.

STEP 2. Make sure that all IGN RET-ADV/LOAD values below boost are 0.

STEP 3. Start the engine and keep it running around 1000 rpm.

STEP 4. Connect a timing light.

STEP 5. Change the MAGNET POSITION value until the timing light reads 10 degrees BTDC.

Once the MAGNET POSITION is set, it does not have to be changed again- it is only to tell the ECU what the "distance" between the #1 MAGNET and Hall sensor is. Once the above 5 steps are completed, you can program any of the ignition values.

MAGNET POSITION may need to be adjusted if the Hall sensor is removed for engine repairs if you have the adjustable type. After it is installed again, the above procedure should be completed again so the ignition timing is the same as before.

SERIOUS ENGINE DAMAGE CAN OCCUR with improper values entered. Excessively retarded timing can cause high exhaust gas temperatures while advanced timing can lead to pre-ignition and detonation. **Default values may not be correct for your engine!**

RPM IGNITION

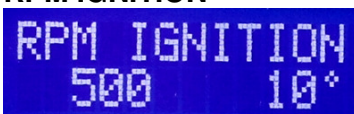

RPM IGNITION
500 10°

This is where the main ignition programming of the system is done. For example, if you want timing at 20 degrees BTDC at 2500 RPM go to RPM IGNITION 2500 and enter 20. You should have knowledge of what your particular engine needs for timing. Lycoming standard 360/540 usually 25 degrees max, 390/580 usually 20 degrees max. If your engine has higher compression and running MOGAS then timing is usually less than the standard. Rotax typical timing is 26 degrees max. Again custom engines may need different timing.

Lycoming new engine break-in: Limit timing to 18 deg for angle valve engines and 20 deg for parallel valve engines. **Adjust your RPM Fuel ignition accordingly!** Dual ECU, don't forget to program B ECU!

Detonation and Ignition timing:

The fuel/air mixture normally burns at a uniform rate within the combustion chamber however if the rate of pressure or temperature rise becomes excessive, detonation can occur. This is the spontaneous explosion of the remaining mixture sometime after the spark event occurs. The result is a rapid and excessive pressure and temperature rise within the chamber, which can often lead to broken ring lands on the piston. Having the ignition timing too far advanced for the fuel octane is the leading cause of detonation, running the AFR too lean also contributes to detonation. You are not likely to be able to hear detonation over the noise of the propeller and exhaust in an airplane so you must program the ECU so that detonation cannot occur in the first place. Too much timing, high compression, and low octane fuel can all contribute to detonation.

IGN RET-ADV/LOAD



IGN RET-ADV/LOAD
25.9 0° RETARD

This parameter allows programming of 64 points of ignition retard and advance with reference to load on the engine. Load information is from the MAP sensor. RET refers to retard, and ADV refers to advance.

On systems using 1 bar MAP sensors all the IGN RET-ADV/LOAD values are set to zero from the factory. Systems with 2 or 3 bar MAP sensors have some retard programmed in higher MAP ranges.

Adding retard in high ranges of IGN RET-ADV/LOAD will help prevent detonation on turbo or high compression normally aspirated engines. Push the +10 or +1 buttons to increase the amount of ignition retard. If too much retard is programmed, power output from the engine will be reduced significantly, and detonation may still occur. Total ignition timing should not be less than 15 degrees, since this could shorten the life of some engine components.

Advance can be programmed by pushing the -1 and -10 buttons on the programmer.

To program ignition timing, two parameters RPM IGN and IGN RET-ADV/LOAD are used.

Important- Total timing is a result of the RPM IGNITION value minus any RETARD or plus any ADVANCE.

Values for IGN RET-ADV/LOAD are limited to a maximum 25 degrees advance, and a maximum 25 degrees retard.

LCD Brightness and Contrast



LCD BRIGHTNESS 7 LCD CONTRAST 5

There are 8 settings for the LCD backlighting brightness, from 0 to 7. Use the +1/-1 buttons to increase or decrease brightness for ambient cockpit lighting conditions.

There are 16 contrast levels available, from 0 to 15. This feature can help optimize viewing at different viewing angles and also during temperature extremes. High temperature can affect the contrast so an adjustment may be needed to compensate. Use the +1/-1 buttons to increment or decrement the setting.

Setup Mode, (hidden settings)

```
SETUP MODE ENTRY  
ENTER=+1 EXIT=<<
```

Setup Mode is like a sub menu of windows that aren't commonly changed. Several windows in here are used to configure the system for particular applications. Press +1 to enter Setup Mode **but don't change any settings such as Config numbers**. Some other settings can be changed by the end user. Press the << key to exit Setup Mode. Windows shown below here are accessed in Setup Mode.

Optional Fuel Flow Output to Engine Monitors

SDS EM-6 has the capability to output a fuel pulse signal similar to electro/mechanical flow meters. This capability is also activated through a discrete PIN number for each individual software burn# once the option is paid for.

Output to your engine monitor is via the brown wire on pin 2 of the injector drive harness plug.

In SETUP MODE, (see setup mode section), scroll right with the > button until you have this windows displayed:

```
SETUP FUEL PULSE  
OUT 340
```

SETUP FUEL PULSE OUT. This window does two functions.

1. The value set here calibrates the output to the engine monitor to fine tune the fuel flow and totalizer amounts depending on injector flow rate. The normal range of values is about 150 to 450. Maximum is 655. **A higher number here = a lower displayed fuel flow**. Use the +/- 1 button to change the value.
2. Testing the FuelFlow output. For V33.0+ software when you have the programmer in this window, the SDS ECU will constantly output test pulses so that you can check your Fuel Flow instrument for function without having to run the engine. Test pulses are fairly high frequency so your instrument may go up to its maximum readout which is okay as we are just looking for indication other than zero, not any particular amount of FF.

Some brands of instruments may require pullup resistors installed between their inputs and 5V or 12V consult their documents for details. If your FF gauge needs a resistor for any of the traditional flow transducers then it will need a resistor for SDS to work with it. Testing on a Garmin G3X showed the FF move up to max in about 2-3 seconds. You cannot calibrate using this method only just prove that your FF instrument is seeing the pulses. If you have no FF showing then the instrument likely needs a pullup resistor enabled in its software or connected on the rear where wires attach.

We can provide you with an **approximate** value to enter for your injector type. Default values are 340 for the most commonly used 46lb injectors, and 260 for the 60lb injectors. **Fine tuning and calibration of this value is up to the user. Never rely on the fuel flow readings or totalizer amount until calibration tests verify the accuracy of the displayed information!** For Dynon and Garmin engine monitors, we recommend a value of 28,500. You can tweak either the SDS or EFIS values to calibrate.

To calibrate, on aircraft with two fuel tanks, we recommend filling the tanks and doing all ground running, takeoff and climb on one tank. Once you get to cruise altitude and set cruise power, switch tanks and fly for one hour, preferably at the same power setting, note the displayed FF. Switch to the other tank at the one hour mark and use this tank for the rest of the flight and ground running prior to shutdown. Refill the cruise tank first and note the amount taken. See how well this compares with the indicated FF in cruise. Fill the other tank and see how the total amount taken agrees with the totalizer amount. Tweak as required several times until you're satisfied with the accuracy of the displayed amounts.

Scroll right one more place to see:

```
SETUP FUEL PULSE  
INJ LAG 1180
```

SETUP FUEL PULSE INJ LAG. This calibrates the ECU for injector latency or lag time which is the amount of time it takes for the injector to open after current is applied to it. This number is usually between about 1000 and 2000. We can provide you with the number to enter for the 2 types of injectors we offer.

```
SETUP INJ TEST  
CH PRESS +1
```

This makes injector do test pulses for about 10 seconds. Intended for troubleshooting a no start condition. Do this only with your fuel pump Off!

Ignition Test

```
SETUP IGN TEST  
CH PRESS +1
```

This makes the Coilpacks generate spark on all coils without having to crank the engine. **Disconnect all spark plugs and put a screwdriver inside each plug wire and put close to chassis ground with a ¼" gap to check for spark.** The test runs for about 10 seconds sparking about 1 time per second. Don't do this test with the plug wires connected to the engine! This is meant only for troubleshooting in a no start situation.

```
SETUP MOLEX PIN1  
FUEL PUMP RELAY
```

Details coming soon. Can also be used to time delay a relay controlling wideband +12 power.

```
SETUP AFR OFFSET  
0
```

For the Ballenger wideband this should be set to 249. Others set to zero but if your wideband display does not match SDS O2 display then adjust accordingly. 0 and up is positive offset, and 255 and below is negative offset.

Setup Baro Fuel Comp(ensation)

```
SETUP BARO FUEL  
COMP*1.5%/1000FT
```

Default is 1.5%, best leave alone unless expertly adjusted.

Setup Molex pin 10 (no photo)

Selects Molex pin function for pin9 of 16 pos Molex on EM-6 ecu. Either Knock or Octane. Default will be Octane for aircraft since knock is not used on aircraft.

Setup Molex pin 9 (no photo)

Selects fan relay function or Auxin2 function. Aux in 2 will be for Closed Loop Target & switch operation. See Electrical section.

SetupDB25Pin22Tach

Changes pin22 output to 1 pulse per engine rev. Normal setting is default = 2pulses 4cyl, 3 pulses 6cyl.

Setup Close Loop Min Volts. Default is 20. Scale is $20/255=0.8$ volts. This may help to block closed loop function if the Wideband is not turned On yet, not fully warm/ready, or not outputting and voltage for some reason or the input to SDS is not connected to the wideband controllers output wire.

Setup APExtra(no photo)

Three windows control extra injections along with Accel Pump action. These numbers help prime the engine with extra fuel before startup and help with Acc Pump throttle response.

*****end of Setup Mode instructions. *****

Default Protection Values (Important)

You may have noticed that there are some strange values entered in your ECU(s) at the far ends of the MAP and temp sensor ranges. These are there to allow the ECU to continue to run the engine at near full power in the event of a shorted or open MAP or temp sensor failure. **Do not change these values!** These are in ranges that the ECUs will never operate in during normal circumstances and will not affect day to day running of the engine. These are zeroes at the coldest Engine Temperature range, and 100's in the bottom few Manifold Pressure ranges.

RPM, MAP, Fuel Delivery, Duty Cycle, Injector concerns

If your mixture still leans out under high power conditions no matter how large your MAP and RPM values are, the system is not at fault. Check for fuel delivery problems. Check the duty cycle first in gauge 2 mode at full power. If it's over 100%, you have a problem with the injectors, pump or regulator. **If your fuel pressure does not keep up with demand, the engine will not run correctly no matter how you program the system.** If your injectors are too small, the same thing applies. At full throttle and high rpm, the mixture should be fairly rich- around 10.5 to 12.5 AFR.

If your values go all over the place with huge steps or deviations, you are probably doing something very wrong. Most well mapped engines have smooth transitions from one step to the next. Look at the sample maps in your manual. If you are really stuck, send us your values, and we can usually suggest some constructive changes.

Basic Dual ECU Operation

On dual ECU setups and dual plug engines, each ECU runs one set of spark plugs.

On dual 4 cylinder systems, the Primary ECU is intended to run the injectors as only it has the full sensor suite. The Backup ECU only has the crank and MAP sensor needed to keep the engine running. It has no temp or TPS sensors or mixture knob connection..

6 cylinder dual systems have full sensor suites for each ECU. It's intended to fly on Both under normal conditions. Each ECU drives 3 injectors and one set of spark plugs. If you switch to either Primary or Backup only, that ECU will fire all 6 injectors and one set of plugs.

Duplicating values into the Backup ECU.

Dual ECU 4cyl systems: In the backup ecu set the Acc Pump Sense to 1, Acc Pump Lo RPM and Acc Pump Hi RPM to **zero**, due to the backup ecu not being connected to the Throttle Position sensor.

Note that Magnet position values are different in dual ECU setups.

On dual 6 cylinder setups, it's most important that all values except Magnet Position are duplicated in each ECU since they share fueling duties when in Normal Mode.

Dual 4 Cyl Fuel ECU Switch

This toggle switch activates relays which switch operation of the injectors from the Primary ECU to the Backup ECU. This switch only affect the injectors not the ignition.

Dual ECU Ignition operation

In normal operation, one ECU board is always firing the top spark plugs, the other fires the bottom plugs. If one ECU board fails, you'll lose function of one ignition coilpack and set of spark plugs but the engine should continue to run on the other coilpack/spark plugs.

4 Cyl Dual ECU recommended checking prior to flight

Fuel injection check:

Start the engine with the FUEL ECU switch in the Primary position. Let the engine warm up some to where it has a smooth and stable idle speed. Switch the FUEL ECU selector switch from Primary to Backup. If the engine continues to run, both ECUs are working and both are able to drive the fuel injectors. Put this switch back to the Primary position.

Ignition check: Switch Off the Ignition coil power to the #1 coil pack. Switch that one back On, then switch Off #2 coil pack power. If the engine runs with either switch in the Off position, then both coil packs are working. **Be sure to check that both coil power switches are in the On position prior to takeoff.**

6 Cyl Dual ECU Pri/Normal/Bak switch

The 6 cylinder dual system has a 3 position ECU selector switch connected to the Injector Relay Box 6cyl which will switch fuel injector control between each ecu board or to both ecu boards.

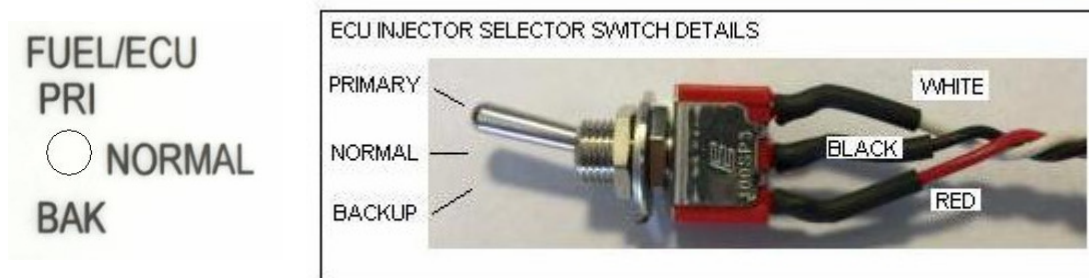

The 3 switch positions operate in the following ways:

NORMAL position: The Primary and Backup ecu are each controlling 3 injector outputs. This provides the ability to trim fuel mixture in each cylinder using the SDS programmer trim screens in the Pri and Bak ECU's..

PRIMARY position: Makes the injector relay box switch all 6 injectors over to the Primary ecu board. This disconnects the Backup ecu fuel injector outputs from the injectors.

BACKUP position: Makes the injector relay box switch all 6 injectors over to the Backup ecu board. This disconnects the Primary ecu fuel injector outputs from the injectors.

In the PRIMARY or BACKUP position, each working ECU will continue to fire one set of plugs and all 6 injectors in pairs (1-4, 2-5 and 3-6), rather than individually as they do with the switch in the BOTH position.

In the event you have a rough running engine or suspect an ecu or sensor problem move the switch to Primary or Backup to see if the engine runs smoother. This would indicate there is a problem with one ecu or its sensors.

6 Cyl Dual ECU recommended checking prior to flight

Fuel injection check:

Set the Fuel/ECU switch in the Normal(middle) position, and start the engine. Let the engine warm up a bit and when idle is smooth and stable move the Switch to the PRI position for several seconds, then move the switch to the BAK position. The engine should stay running smoothly in all 3 switch positions, if not there is a problem. The Fuel/ECU switch should be in the Normal(middle) position for flight. We don't recommend you switch the ECUs to Primary or Backup in flight unless the engine stops or runs rough.

Note that this switch does NOT control which ignition coil pack is running since both coil packs run all the time. Coil packs can only be controlled or shut off via their 12 volt power source.

Ignition check: Switch Off the Ignition coil power to the #1 coil pack. Switch that one back On, then switch Off #2 coil pack power. If the engine runs with either switch in the Off position, then both coil packs are working. **Be sure to check that both coil power switches are in the On position prior to takeoff.**

If running in Primary or Backup positions its best to switch OFF your LOP (Lean of Peak) switch. Also depending on cyl trim settings you may need to richen the mixture with the mixture knob, since trim settings from cylinders would be applied to other cylinders due to pairing of injector outputs.

Dual Fuel Pump Operation

If you have the dual fuel pump module, you want to verify that each pump supplies sufficient fuel pressure before flight. Depending on the fuel pressure regulator used and the setting, static fuel pressure (engine not running) will normally be between 40 and 50 psi. With engine running at idle, fuel pressure should be 30-40 psi due to vacuum acting on the regulator.

For takeoff, landing and operation below 1000 AGL, most people prefer to have both pumps running. The second pump may be switched off above this altitude. You can use pump 1 on odd days of the month and pump 2 for even days to split pump wear. Note that fuel pressure may rise a few psi with both pumps running due to the very high volume delivered. The regulator may not be able to pass enough fuel through the return line to hold the pressure down, especially at idle. This may result in slightly richer operation but is usually no concern.

Electrical current draw specifications

Item	Current Draw Range (Amps)
ECU (each)	.08-.13
Fuel Pump (each)	4-6
Injectors (each pair of 2)	2-4
Injectors (each bank of 3)	3-6
Injectors (each)	1-2
Coil Pack 4 cyl. (each)	2-3
Coil Pack 6 cyl. (each)	2-4
Check Engine Light	.1
Advance Switch Power	.1
RPM Switch Relay Power	.3

Typical Lycoming 360/540 injector current draw is about 2 amps for 360 and 3 amps for 540, when running standard 46lb/hr injectors supplied with almost every kit. The injectors are running approximately 50% duty cycle.

EM-6 Aviation System ECU Pinouts

DB25

Pin 1	Switched 12V power ECU, Red 20 ga.
2	TPS 5V
3	Knob 5V
4	MAP 5V
5	Future use, brown.
6	MAP signal
7	Air temp +
8	Coil trigger 8 cyl. Channel A
9	Coil trigger 4 cyl./6 cyl. Channel A, Channel C 8 cyl.
10	Coil trigger 6 cyl. Channel B, Channel D 8 cyl.
11	Coil trigger 4 cyl. Channel B, 6 cyl. Channel C, 8 cyl. Channel B
12	5V tach output, Green 20ga
13	Ignition advance/ LOP switch enable input, blue 20 ga.
14	Mixture knob ground
15	MAP ground
16	Air temp ground
17	Engine temp ground
18	ECU ground, black 20 ga.
19	Mixture knob signal
20	Engine temp +
21	TPS signal
22	12V tach output, yellow 20 ga.
23	Future use, purple, not used now, for future use.
24	O2 sensor input, gray 20 ga.
25	TPS ground

DB9 Hall Sensor

Pin 3	Ground
4	Trigger signal
5	+5V
8	Synch signal

Wire colors Sheathed Cable

2 conductor- White + or power, Blue ground

3 conductor- Orange + or power, White signal, Blue ground

4 conductor (Hall sensor) Orange +5V, White trigger signal, Blue ground, Green synch signal

Diagnosing Problems and Troubleshooting

Check Engine Light

Software in the EM-6 can detect some but not all problems with the following sensors:

MAP sensor: Power or ground connections, broken or intermittent.

Engine and air temperature sensors: Open or short circuit.

Hall sensor/RPM error problem: Caused by missed magnet or vibrating hall sensor mount.

Low battery voltage: If below 12.5 volts, will turn on the LED.

Lean warning(if enabled): If lean mixture occurs at high throttle for 2 seconds.

Check Gauge modes for "ERR" readings to see which sensor has a problem.

RPM, temperature, MAP sensor errors, even if occurring for a very short period of time, will leave the check engine light turned on so the user can see there was a problem. You can attempt to clear the error and light by pressing the +10 button in Gauge1 mode, and if the light stays lit, the problem still exists. If the light turns off, the problem may be intermittent and you should check electrical connections at the faulty sensor, or check hall sensor alignment if gauge mode shows an RPM ERR message. **Never fly the aircraft if the check engine light stays on after starting and the battery voltage is above 12.5V.**

Low battery voltage will not lock the light on, instead the light will turn off when the battery voltage goes above 12.5 volts. It will be normal to have the light turned on while the ignition is turned on but the engine is not running, since battery voltage is usually under 12.5 volts.

Some problems cannot be detected such as MAP sensor broken signal wire. Just because the LED is turned off doesn't mean everything is good with the system. SDS cannot detect faulty O2 sensors. SDS cannot detect all sensor problems.

Water entering the computer can be a common problem with improper installations. Remove the lid of the ECU and inspect the inside for water, or corrosion. Water, which has dried, leaves a white residue on the circuit board. Water may still be present under or inside connectors, which will cause random symptoms and running problems. The EM-6 may operate fine once dried out or may need to be sent in for repair.

The four gauge modes permit monitoring of the primary sensor inputs to the EM-6 in real-time. Rpm should be stable, agreeing with the factory tach. Spurious rpm readings usually indicate ignition or triggering interference, or a Hall sensor problem. **Don't attempt to fly with unstable rpm readings or RPM ERR codes displayed in the programmer.**

Manifold pressure should increase as the throttle is opened at a given rpm. Opening the throttle should increase the TP number. The TP number should not change if the throttle is not moving.

Engine and air temps should roughly agree with the ambient temperature if the engine has been shut down overnight.

Switching to gauge 2 mode allows you to monitor the mixture knob position. It should read 0 at the straight up position. You should be able to get the reading to change from -49% to +49% by turning fully to both stops.

In Gauge 2 mode, acceleration pump operation is verified by snapping the throttle open. The AP number should rapidly increase until movement is stopped then the number should rapidly decrease to 0 again. The AP number should always be 0 unless the throttle is being moved. Rough running and a fluctuating TP or AP reading without throttle movement indicates a TPS problem usually. **Don't attempt to fly with unstable TP/AP readings displayed in the programmer.**

When encountering problems which can be identified to be linked with a specific area or function, always go to that section in the manual first and re-read it.

Symptoms- Fuel Problems

Engine will not start:

1. Check engine compression
2. Check FUELCUT/MANPRESS parameter. Should read NO LIMIT.
3. Try turning mixture knob richer while cranking. START values might have to be increased.
4. Check all connections on EM-6 main harness, ignition.
5. Check both ground wires from EM-6, one from main harness and one from injector drive harness.
6. Check MP reading in Gauge1 mode. If between 0 to 10 inches, check MAP sensor connector for broken wires, or bad contact in the terminals. Try new MAP sensor
7. Check for +12V to injectors while engine is cranking.
8. Check if the programmer goes blank during cranking. Check battery voltage. Should be at least 9 volts while cranking, and 12.0 volts when not cranking.
9. Check for spark.
10. Check ignition timing while engine is cranking.
11. Check if the fuel pump is running.
12. If fuel pump relay is used, check connections.
13. Check for fuel flow out of regulator drain to return of fuel tank.
14. Check for injectors clicking.
15. Check FUELCUT/RPM parameter. Should read NO LIMIT, or a high RPM.
16. Check compression and camshaft timing.
17. Check Hall sensor gap and alignment with magnets.
18. If using a noid light, make sure all of the injector plugs are unplugged from every injector. Check +12v supply to injectors and check grounds on ECU. Use noid lights as a last resort. LED noid lights are much better than incandescent.

It is highly unlikely that there is a problem with the ECU, since many ECU's in the past have been returned with "no fuel" symptoms, but they work just fine so check all of the above carefully.

Will not rev up or has Miss:

1. Check ACCPUMP values. May be too high.
2. Check AP number in gauge 2 mode. Should be zero when throttle is stable. Check this with engine running. May only show up at certain RPM's.
3. Check for leaking fuel pressure regulator diaphragm. If fuel in vacuum reference hose then replace the regulator.
4. Check for bad values in RPM or MAP parameters. Could be crossing a bad value anywhere.
5. Hall sensor mount is vibrating. Stronger bracket required. Watch RPM reading in gauge 1 for ERR message.
6. Check FUELCUT/MANPRESS and FUELCUT/RPM parameters.
7. Check resistance of all spark plug wires. Possible poor crimp at the end of a wire causing arcing.
8. Try a different brand of spark plug wires.
9. If Knock sensor is being used, Knock Sense value may be too high. If there is no knock sensor on the SDS, system set Knock Sense to 1, and Knock Retard to zero.

Unstable RPM reading in Gauge 1 mode.

Check hall sensor alignments and magnets. Bracket must not vibrate or flex.

Idle speed too high:

1. Throttle stop may be set to hold open throttle plate. Make adjustment.
2. Vacuum leak.

Idle speed too slow:

1. Mixture could be too rich or too lean. Adjust fuel values for fastest idle speed, then if idle speed is still too slow, adjust throttle stop or air bypass screw for faster idle speed.

Rough idle:

1. Bad ignition wire arcing to ground.

2. Mixture needs to be rich for best idle. Try adjusting fuel values until too rich then lower the values until engine is smooth.
3. Bad injector or bad cylinder. Unplug each injector to isolate.
4. Do engine compression check. Look for engine mechanical problem.
5. Bad connection at MAP sensor. Unplug and plug in the connector a few times.
6. MAP sensor vacuum line not connected or connected to the wrong area on the intake manifold or throttle body.
7. See below, Not Running on all Cylinders section

Cuts Out at High Power:

1. Fuel pump not adequate.
2. Injector flow rate too low.
3. Check FUELCUT/MANPRESS parameter. Adjust and try again or set to NO LIMIT.
4. Fuel lines or filter plugged or too small.
5. Check for fuel flow volume out of regulator drain to return of fuel tank.
6. Engine is crossing an improper value.
7. Fuel tank not vented. Remove filler cap check for suction.
8. Bad injector ground connection. Do Ohms check from chassis to pin 8 of white connector.
9. Check fuel pressure, should be 45-50 psi.
10. If system is using a knock sensor then Knock sensor may be activating and reducing the ignition timing too much. Try higher octane fuel or try lower Knock Sense value.
11. Reduce spark plug gap. Ignition voltage may not be high enough for stock plug gap specification.
12. LOP engaged with possible unusual settings. Check LOP settings and also Switch logic, wiring and connections.

Not Running on all Cylinders:

1. Check each injector for clicking sound.
2. Not an ignition coil problem if only one cylinder is dead, so likely mechanical, injector, or wiring problem.
3. Bad ignition wire arcing to ground.
4. Bad spark plug.
5. 6cyl, Check 7-pin connector at coilpack assembly to make sure connector is plugged in fully, make sure it is latched on both sides. 6cyl, check coil pack 4 pin connector to make sure its latched.

Runs but lacks power:

1. Check camshaft timing.
2. TPS vibrating and is activating the ACC PUMP function. Watch AP in Gauge2 mode. Should read zero when throttle is steady. Set both ACC PUMP values to zero and see if problem goes away.
3. Check TPS hookup and ACC PUMP values for too high a value.
4. Mixture far too rich or lean. Increase or decrease all RPM FUEL values to correct or adjust knob.
5. Fuel tank not vented. Remove filler cap, check for suction.
6. Check timing with a timing light, magnets could be mounted incorrectly.
7. (F only). RPM IGN (ignition timing) values too low.
8. Make sure closed loop is OFF
9. LOP engaged with possible unusual settings. Check LOP settings and also Switch logic, wiring and connections if equipped with a Toggle Switch for LOP enabling.
10. If system is using a knock sensor then Knock sensor may be activating and reducing the ignition timing too much. Try higher octane fuel or try lower Knock Sense value.

Programmer display is blank:

1. Check power and ground connections on black and red wires of main harness.
2. TPS connections are wrong. Try unplugging the TPS and MAP connectors.
3. Programmer cable is damaged.
4. If ECU is a dual board unit, only the primary provides power to the programmer, so the Primary ecu board must be powered up for the programmer unit to display data and operate.

SDS EFI in Window:

1. TPS connections are wrong. Try unplugging the TPS cable.
2. Power has been interrupted or EM-6 has reset.
3. Do resistance check of ignition wires. Possible bad crimp at end of wire.
4. Spark plug wires causing EMI (interference). Try different brand of wires. **Must use Suppression type plug wires with SDS.**
5. Check for loose spark plug wires.
6. Move sensor wires away from ignition.
7. Don't ground solenoids or other devices at the same place as the ECU ground.
8. Move ECU further away from engine.
9. Solenoid switching may cause this. Disable any solenoids, relays, motors etc. Diodes can be connected across solenoids to absorb electrical spikes. Call us for help.
10. Using non-resistor spark plugs. **You must use resistor plugs with SDS.**

Strange characters or black bar across the top of the LCD window:

1. Programmer cable damaged, common problem. New cable can be found at most computer stores.
2. Measure the resistance of all spark plug wires. Possible poor crimp at the end of a wire causing arcing, or bad insulation causing arcing to ground. Replace or repair any wire that has a much higher resistance than the others.
3. Interference from spark plug wires. Try different brand of plug wires. **Must use Suppression type plug wires with SDS.**
4. Programmer data being interfered with. Don't run cable with other wiring.
5. Loose programmer cable connection.
6. Change spark plugs to resistor type. **Non-resistor types cause electrical noise.**
7. Programmer was plugged into ECU AFTER the ECU was powered up.
8. Move ground connection to EM-6 to a different location.
9. Check main harness connection to ECU.

Engine fills up with fuel:

1. Bad ECU ground wire connection.
2. Check for leaking fuel pressure regulator diaphragm.

Won't run over 2000 rpm:

1. Check FUELCUT BELOW TP limit. Aircraft applications set to NO CUT.

Will not rev up or has Miss:

1. Check ACCPUMP values. May be too high.
2. Check AP number in gauge2 mode. Should be zero when throttle is stable. Check this with engine running. May only show up at certain RPM's.
3. Check for leaking fuel pressure regulator diaphragm. If fuel in vacuum reference hose, replace the regulator.
4. Check for bad values in RPM or MAP parameters. Could be crossing a bad value anywhere.
5. Hall sensor mount is vibrating. Stronger bracket required. Watch RPM reading in Gauge1 for ERR message.
6. Check FUELCUT/MANPRESS and FUELCUT/RPM parameters.
7. Check resistance of all spark plug wires. Possible poor crimp at the end of a wire causing arcing.
8. Try a different brand of spark plug wires. **Must use Suppression type plug wires with SDS.**
9. If Knock sensor is being used, Knock Sense value may be too high. If there is no knock sensor on the SDS system set Knock Sense to 1, and Knock Retard to zero.

Unstable RPM reading in Gauge 1 mode.

1. On "D" systems using a tach wire to the coil, some types may cause double triggering in the tach circuit of the ecu. You may have to install a Hall sensor to give the ECU a clean tach signal.
2. On "F" systems, check Hall sensor alignments and magnets. Bracket must not vibrate or flex.

Idle speed too high:

1. Throttle stop may be set to hold open throttle plate. Make adjustment.
2. Vacuum leak.

Idle speed too slow:

1. Adjust throttle stop screw.
2. Mixture could be too rich or too lean. Adjust fuel values for fastest idle speed, then if idle speed is still too slow, adjust throttle stop or air bypass screw for faster idle speed.

Rough idle:

1. Bad ignition wire arcing to ground.
2. Mixture needs to be rich for best idle. Try adjusting fuel values until too rich, then lower the values until engine is smooth.
3. Bad injector or bad cylinder. Unplug each injector to isolate.
4. Do engine compression check. Look for engine mechanical problem.
5. Bad connection at MAP sensor. Unplug and plug in the connector a few times.
6. MAP sensor vacuum line not connected or connected to the wrong area on the intake manifold or throttle body.

Cuts Out at High Power:

1. Fuel pump not adequate.
2. Injector flow rate too low.
3. Check FUELCUT/MANPRESS parameter. Adjust and try again or set to NO LIMIT.
4. Fuel lines or filter plugged or too small.
5. Check for fuel flow out of regulator drain to return of fuel tank.
6. Engine is crossing an improper value.
7. Fuel pressure too high, injectors won't open.
8. Fuel tank not vented. Remove filler cap check for suction.
9. Bad injector ground connection. Do Ohms check from chassis to pin 8 of white connector.
10. Install a fuel pressure gauge.
11. Reduce spark plug gap. Ignition voltage may not be high enough for stock plug gap specification.
12. If system is using a knock sensor then Knock sensor may be activating and reducing the ignition timing too much. Try higher octane fuel or try lower Knock Sense value.

Not Running on all Cylinders:

1. Check each injector for clicking sound.
2. Bad ignition wire arcing to ground.

Runs but lacks power:

1. Check camshaft condition.
2. TPS vibrating and is activating the ACC PUMP function. Watch AP in Gauge2 mode. Should read zero when throttle is steady. Set both ACC PUMP values to zero and see if problem goes away.
3. Check TPS hookup and ACC PUMP values for too high a value.
4. Mixture far too rich or lean. Increase or decrease all RPM FUEL values to correct or adjust knob.
5. Fuel tank not vented. Remove filler cap, check for suction.
6. (F only). Check timing with a timing light, magnets could be mounted incorrectly.
7. (F only). RPM IGN (ignition timing) values too low.
8. Check that closed loop is turned OFF.
9. If system is using a knock sensor then Knock sensor may be activating and reducing the ignition timing too much. Try higher octane fuel or try lower Knock Sense value.

Programmer display is blank:

1. Check power and ground connections on black and red wires of main harness.
2. TPS connections are wrong. Try unplugging the TPS cable.
3. Programmer cable is damaged.

4. If +12V has been accidentally shorted to the ECU case, the circuit board may need repair, due to a broken ground circuit.

SDS EFI in Window:

1. TPS connections are wrong. Try unplugging the TPS cable.
2. Power has been interrupted or ECU has reset.
3. Do resistance check of ignition wires. Possible bad crimp at end of wire.
4. Spark plug wires causing EMI(interference). Try different brand of wires. **Must use Suppression type plug wires with SDS.**
5. Check for loose spark plug wires.
6. Move sensor wires away from ignition.
7. Don't ground solenoids or other devices at the same place as the ECU ground.
8. Move ECU further away from engine.
9. Solenoid switching may cause this. Disable any solenoids, relays, motors etc. Diodes can be connected across solenoids to absorb electrical spikes. Call us for help.

Strange characters or black bar across the top of the LCD window:

1. Programmer cable damaged, common problem. New cable can be found at most computer stores.
2. Measure the resistance of all spark plug wires. Possible poor crimp at the end of a wire causing arcing, or bad insulation causing arcing to ground. Replace or repair any wire that has a much higher resistance than the others.
3. Interference from spark plug wires. Try different brand of plug wires. **Must use Suppression type plug wires with SDS.**
4. Programmer data being interfered with. Don't run cable with other wiring.
5. Loose programmer cable connection.
6. Change spark plugs to resistor type. Non-resistor type cause electrical noise.
7. Programmer was plugged into ECU after the ECU was powered up.
8. Move ground connection to ECU to a different location.
9. Check main harness connection to ECU.

Engine fills up with fuel:

1. Bad ECU ground wire connection on DB25 main harness. Move ground to another place or clean connection.
2. Check for leaking fuel pressure regulator diaphragm.

Won't run over 2000 rpm:

1. Check FUELCUT BELOW TP limit. Set to a lower value, or set to NO CUT.

If problems persist, and you are calling for help, we may be able to help you better if you write down your values and send them to us. This may help narrow down the problem much faster. The last page in this manual is for writing down your values.

Don't ground the SDS ECU to the engine. Engine ground may be noisy and cause the ECU to malfunction. Ground it to the chassis of the aircraft or to a grounding buss. Be sure to sand off any paint where the connection is.

Make sure the ECU is permanently grounded to the airframe and never put a switch in any ground circuit of any SDS component. If a component needs a switch, it should always be on the positive(+) wire.

Spark plugs, wires and Interference Problems

Always use resistor spark plugs.

Always use radio suppression type spark plug wires. NEVER use solid core wires.

Recommended wires:

MSD superconductor.

NGK.

OEM or factory carbon string.

Accel 8.8 yellow
Taylor Spiro-Pro

For engines with coil-on-plug ignition coils be sure to use resistor type spark plugs. Resistor plugs usually have 5Kohms resistance. NGK resistor plugs will have the letter R in the part number. Non resistor plugs can create electrical noise and cause interference problems.

Ignition interference problems usually show up as strange characters in the programmer screen, rough running, misfiring or an RPM ERR code in Gauge 1 mode.

Factory default programmed values

If you have running problems or have trouble programming the system, you may want to restore all the factory values. You will have to scroll through all the ranges in the programmer and check or re-enter the factory values. Factory values are shown in the following pages. Be sure to select the proper page. There is a page for each of the three different MAP sensors, so you must know which MAP sensor you have.

Tech Help

For technical assistance contact your dealer or:

Racetech Inc.

#5, 304 Noorduyn Park (Springbank Airport)

Calgary, Alberta, Canada T3Z 3S8

Phone 403-671-4015

E-mail racetech1@telus.net Website: www.sdsefi.com

When calling for help you should know which system you have. We offer 2 different systems, "D" is fuel only, "F" fuel & multi coil ignition.

Warranty and Use of Products

Since SDS cannot control the installation or use of its products, we accept no responsibility for damage, loss or personal injury while using our products. By using SDS products the user understands and accepts this. All SDS electronic components are guaranteed to be free from defects in workmanship and material for a period of 3 years from the date of sale to original purchaser if installed according to this manual. SDS shall make the sole determination with regards to all warranty claims.

Components are not covered if they have been altered in any way, physically damaged, subjected to moisture or incorrectly connected.

Repairs

- 1. Please call or email Racetech before returning any SDS components for checking or repair.**
- 2. Please ship parts to us via FEDEX or UPS AIR or regular US Post.**
- 3. DO NOT ship parts to us via UPS ground. You'll be responsible for brokerage fees otherwise.**
- 4. Please write on the box and waybill "FOR WARRANTY REPAIR, MADE IN CANADA".**
- 5. Items shipped to us for warranty checks or testing which are working properly will be subject to a \$40.00US charge plus shipping.**

Prior authorization is required before any warranty or returned item is accepted. Defective components will be repaired or replaced as soon as possible at the discretion of Racetech.

Returns

No returns are accepted after 30 days and all returned goods are subject to a 15% restocking fee as well as a charge for any damaged components, cut wires or missing items.

Courier Shipping

Items for warranty or repair should be shipped to:

Racetech Inc.

#5, 304 Noorduyn Park (Springbank Airport)

Calgary, Alberta, Canada T3Z 3S8

Phone 403-671-4015

E-mail: racetech1@telus.net Website: www.sdsefi.com

Please call or email us before sending parts for checking or repair.

Please write on the box and waybill "FOR WARRANTY REPAIR, MADE IN CANADA"

Mail Shipping

Items for warranty or repair should be shipped to:

Racetech Inc.

276 Hidden Valley Grove NW

Calgary, Alberta, Canada T3A 5W9

Phone 403-671-4015

All SDS software, PCB design and this manual is the exclusive property of Simple Digital System. Unauthorized use or reproduction is a violation of copyright.

Warnings

Warning Regarding Vertical Power VP-X and SDS

It has come to our attention that the VP-X electronic switching/ circuit breaker box does not use average current draw over several seconds to trip breakers like conventional thermal breakers do. It may trip during normal operation due to peak current transients over only a few milliseconds. This can lead the pulsing current of the ignition coils and injectors to trigger the breaker far below nominal current levels. We believe this could cause a serious flight safety issue and engine stoppage. Be sure to set the breaker values on the VP-X far higher than the nominal current draw on these circuits. Be aware that average current draw can increase with rpm and load so ground running may not allow complete testing of this condition if static rpm is lower than flight rpm and engine shutdown could occur in flight. Breakers are to protect the wiring, not the device. We recommend each 4 cylinder coil pack have a rating of at least 15 amps assigned when using the VP-X, each 6 cylinder coil pack at least 20 amps, 4 cylinder injector power at 15 amps, 6 cylinder at 20 amps and 8 cylinder at 25 amps. **These are only recommendations, use this information at your own risk and these values should be thoroughly tested prior to flight at WOT and maximum rpm the engine will see in flight. It's a better idea not to run SDS wiring to a VP-X. Conventional breakers or fuses are preferable.**

Revisions

Jan 25,24 Adjust RPM fuel, change to Adjust RPM Ignition.

July 2/23, grammar.

July 7/23 Lyc top mount coil diagram numbers were wrong.

July 9/23 Clarified Cylinder Trim section

July 14/23 Added battery section

Jan. 7/24 Removed EM-5 references, changed wideband O2 section for AEM 30-0310 use

Feb. 11/24 Added ACS PN for 2.5 inch adapter flange

Default fuel and spark values for a IO360 Lycoming with 46lb injectors.

ABS IN HG						ENGINE		ENGINE		ENGINE	
MAN PRES	VAL	RPM	FUEL VAL	RET/MANPR VAL	RPM	IGN VAL	1/8NPT F	1/8NPT C	TEMP VALUE	START VALUE	
3.72	100	500	165	3.72	0	500	10	302	150	0	9
4.16	100	750	165	4.16	0	750	15	275	135	0	7
4.59	35	1000	165	4.59	0	1000	20	239	115	0	5
5.03	36	1100	165	5.03	0	1100	25	221	105	0	0
5.46	37	1200	165	5.46	0	1200	25	203	95	0	0
5.9	38	1300	165	5.9	0	1300	25	189	87	0	0
6.33	39	1400	165	6.33	0	1400	25	176	80	0	0
6.77	40	1500	165	6.77	0	1500	25	167	75	2	0
7.2	41	1600	165	7.2	0	1600	25	158	70	5	0
7.64	42	1700	165	7.64	0	1700	25	149	65	9	5
8.08	43	1800	165	8.08	0	1800	25	142	61	13	8
8.51	44	1900	165	8.51	0	1900	25	136	58	17	12
8.95	46	2000	165	8.95	0	2000	25	129	54	22	15
9.38	47	2100	165	9.38	0	2100	25	122	50	27	18
9.82	48	2200	165	9.82	0	2200	25	115	46	32	20
10.3	48	2300	165	10.3	0	2300	25	109	43	37	22
10.7	49	2400	165	10.7	0	2400	25	104	40	42	25
11.1	50	2500	165	11.1	0	2500	25	95	35	45	29
11.6	50	2600	200	11.6	0	2600	25	90	32	48	30
12	52	2700	200	12	0	2700	25	86	30	52	33
12.4	54	2800	200	12.4	0	2800	25	79	26	57	36
12.9	56	2900	200	12.9	0	2900	25	72	22	61	39
13.3	58	3000	200	13.3	0	3000	25	66	19	66	55
13.7	60	3100	200	13.7	0	3100	25	59	15	70	64
14.2	62	3200	200	14.2	0	3200	25	52	11	74	70
14.6	64	3300	200	14.6	0	3300	25	43	6	78	85
15	66	3400	200	15	0	3400	25	36	2	84	100
15.5	68	3500	200	15.5	0	3500	25	25	-4	90	130
15.9	70	3600	200	15.9	0	3600	25	14	-10	96	140
16.3	72	3700	200	16.3	0	3700	25	-4	-20	102	170
16.8	74	3800	200	16.8	0	3800	25	-26	-32	108	190
17.2	76	3900	200	17.2	0	3900	25	-58	-50	0	0
17.7	78	4000	200	17.7	0	4000	25				
18.1	80	4100	200	18.1	0	4100	25				
18.5	82	4200	200	18.5	0	4200	25				
19	84	4300	200	19	0	4300	25				
19.4	86	4400	200	19.4	0	4400	25				
19.8	88	4500	200	19.8	0	4500	25				
20.3	90			20.3	0						
20.7	92			20.7	0	ACCPUMFLORPM		40			
21.1	94			21.1	0	ACCPUMPHIRPM		20			
21.6	96			21.6	0	ACCPUMPSENSE		5			
22	98			22	0	START CYCLES		32			
22.4	100			22.4	0	MAGNET POSITION	PRI=97 BAK=88 Single=	92			
22.9	102			22.9	0	KNOCK RETARD		0			
23.3	104			23.3	0	KNOCK SENSE		1			
23.7	106			23.7	0	KNOCK MAX RPM		500			
24.2	108			24.2	0	CL MAP HI			NA		
24.6	110			24.6	0	CL MAP LO			NA		
25.1	112			25.1	0	CL RPM HI			NA		
25.5	114			25.5	0	CL RPM LO			NA		
25.9	116			25.9	0	CLOSED LOOP		OFF			
26.4	118			26.4	0	FUELCUT/MANPRES		No Limit			
26.8	120			26.8	0	FUELCUT/RPM		2900			
27.2	122			27.2	0	FUELCUT BELOW TP		NO Cut			
27.7	124			27.7	0	FAST IDLE SWITCH		NA			
28.1	126			28.1	0	IDLE TP LOCATION		No use			
28.5	128			28.5	0	IDLE FUEL AMOUNT		No use			
29	130			29	0						
29.4	132			29.4	0						
29.8	134			29.8	0						
30.3	136			30.3	0						
30.7	138			30.7	0						
31.1	140			31.1	0						

Write down your values here

MAN PRES	VAL	RPM FUEL	VAL	ENG TEMP	VAL	START	VAL	RPM IGN	VAL	RET/LOAD	VAL
		500						500			
		750						750			
		1000						1000			
		1100						1100			
		1200						1200			
		1300						1300			
		1400						1400			
		1500						1500			
		1600						1600			
		1700						1700			
		1800						1800			
		1900						1900			
		2000						2000			
		2100						2100			
		2200						2200			
		2350						2350			
		2400						2400			
		2500						2500			
		2600						2600			
		2700						2700			
		2800						2800			
		2900						2900			
		3000						3000			
		3100						3100			
		3200						3200			
		3300						3300			
		3400						3400			
		3500						3500			
		3600						3600			
		3700						3700			
		3800						3800			
		3900						3900			
		4000						4000			
		4100				ACCPUMPLORPM		4100			
		4200				ACCPUMPHIRPM		4200			
		4300				ACCPUMPSENSE		4300			
		4400				START CYCLES		4400			
		4500				MAGNET POSITION		4500			
						KNOCK RETARD					
						KNOCK SENSE					
						CL MAP HI					
						CL MAP LO					
						CL RPM HI					
						CL RPM LO					
						CLOSED LOOP					
						FUELCUT/MANPRESS					
						FUELCUT/RPM					
						FUELCUT BELOW TP					
						FAST IDLE SWITCH					
						IDLE TP LOCATION					
						IDLE FUEL AMOUNT					
						O2 TYPE					
						PIN 13 INPUT					
						LEAN WARN					
						TRIM 1					
						TRIM 2					
						TRIM 3					
						TRIM 4					
						CRANK RETARD					
						LOP LEAN FUEL%					
						LOP IGN ADV					
						LOP MAX MP					
						LOP CTRL					